

AD-4981-2570

Flipper Type Rejector





INSTRUCTION MANUAL



A&D Company, Ltd.

WARNING DEFINITIONS

The warnings described in this manual have the following meanings:

 WARNING	A potentially hazardous situation which, if not avoided, could result in death or serious injury.
 CAUTION	A potentially hazardous situation which, if not avoided, may result in minor or moderate injury or damage to the instrument.
	This symbol indicates caution against electrical shock. Do not touch the part where the symbol is placed.
	This symbol indicates the ground terminal.
	This symbol indicates that an operation is prohibited.
Note	Information or cautions to use the device correctly.

© 2020 A&D Company, Limited. All rights reserved.

No part of this publication may be reproduced, transmitted, transcribed, or translated into any language in any form by any means without the written permission of A&D Company, Limited.

The contents of this manual and the specifications of the instrument covered by this manual are subject to change for improvement without notice.

Contents

1. Introduction.....	5
2. Unpacking	6
3. Descriptions of parts.....	8
3-1 Overall view.....	8
3-2 Cables.....	9
3-3 Warning labels	10
4. Assembly.....	11
4-1 Main unit.....	11
4-2 Flipper arm (sold separately).....	14
4-3 Reject confirmation unit (sold separately)	19
4-4 Power supply unit (sold separately)	20
4-5 Flipper rejector arm plate (sold separately).....	24
5. Installation	26
6. Connection	27
6-1 Connecting to the AD-4991 series	27
6-2 Connecting to the AD-4976-H series.....	31
6-3 Connecting to the AD-4971 series	40
6-4 Connecting to the AD-4961A series	44
7. Maintenance.....	48
7-1 Daily check.....	48
7-2 Belt installation/removal	49

7-2-1 Removing the belt..... 49

7-2-2 Attaching the belt..... 51

7-3 Belt meander adjustment 54

7-4 Belt cleaning..... 55

7-5 Flipper arm operating speed adjustment..... 56

8. Specifications 57

9. External dimensions 58

10. List of consumables..... 60

11. Required tools 61

12. Revision History 62

1. Introduction

The AD-4981-2570 is a flipper type rejector that can be used by connecting to the AD-4991 X-ray inspection system, the AD-4976-H metal detector, or the AD-4961A checkweigher. When the AD-4981-2570-39 power supply unit (sold separately) is attached, the AD-4981-2570 can also be used connected to AD-4971 metal detector.

By operating its arm using the air cylinder, the AD-4981-2570 can sort products in two directions: diverted and straight. When an AD-4981-2570-21, AD-4981-FR2570, or AD-4981-FL2570 flipper arm (sold separately) is added, the sorting directions can be increased to three directions: two diverted and one straight.

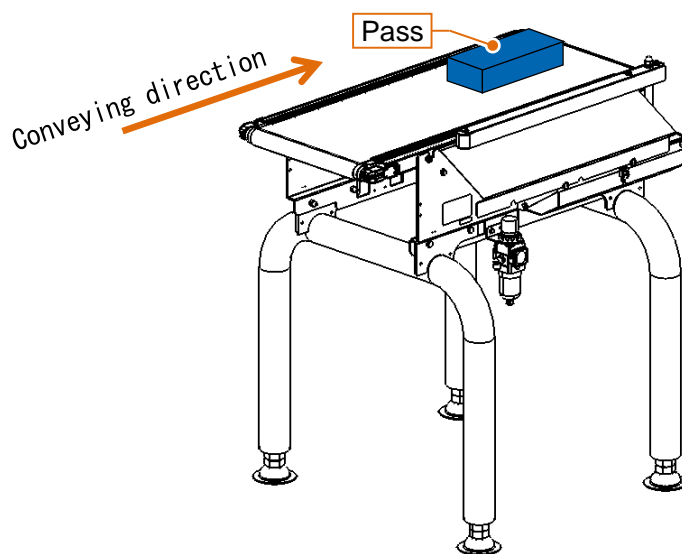

Fig. 1 Image of sorting (conveying products in a straight direction)

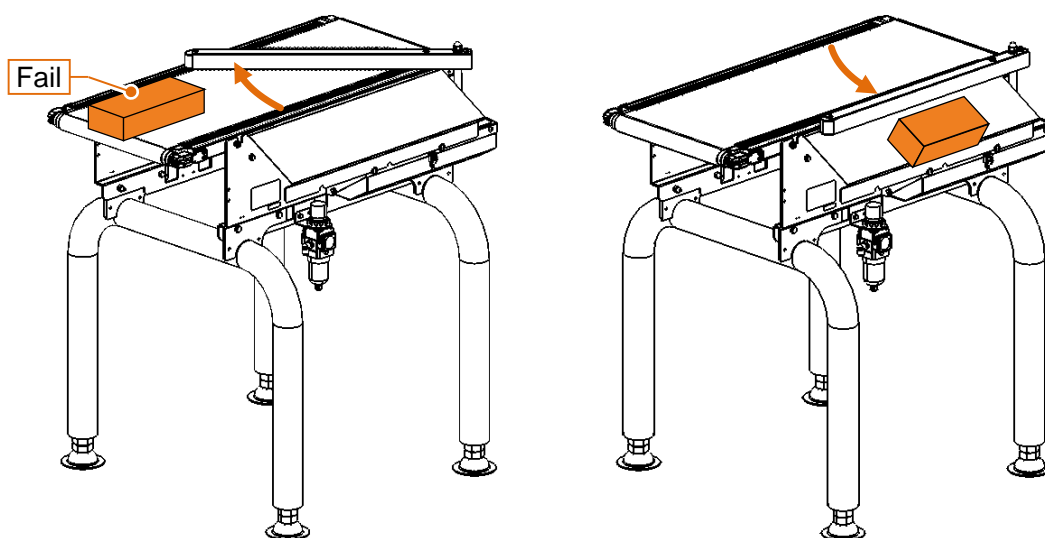

Fig. 2 Image of sorting (conveying products in a diverted direction)

2. Unpacking

Before assembling, make sure that the following items are included in the package and that they are not damaged.

If anything is missing or damaged, please contact your local A&D dealer.

Depending on how you purchased it, your product may be delivered pre-assembled.

Table 1 Packing list (1/2)







Item	External view
Rejector main unit	
Chute plate	
Base unit	
Mounting screws for the base unit (8 pieces, M6, 20 mm in length)	

Table 2 Packing list (2/2)

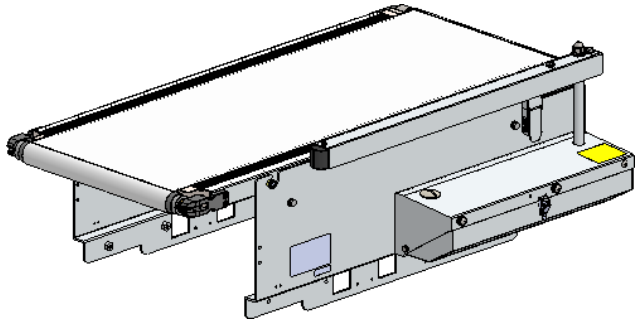
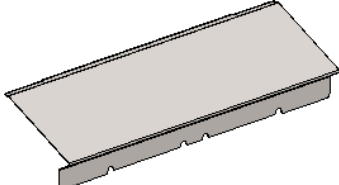
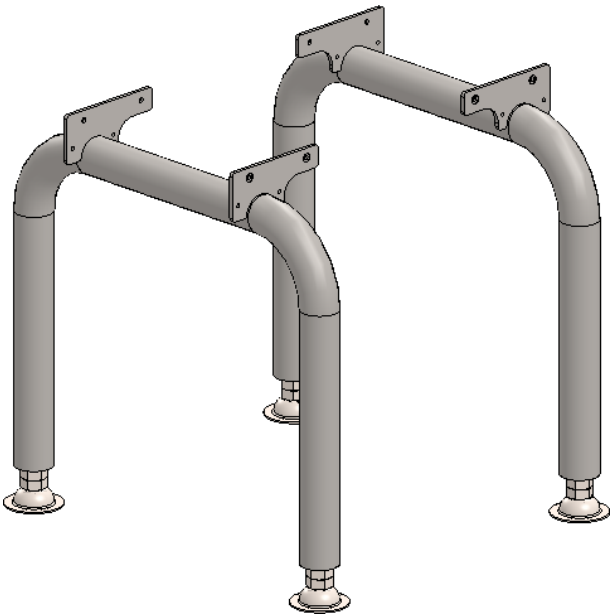
Item	External view
Filter regulator	
Filter regulator bracket	
Mounting screws for the filter regulator bracket (2 pieces, M4, 8 mm in length)	
24 V crossover cable	

3. Descriptions of parts

3-1 Overall view

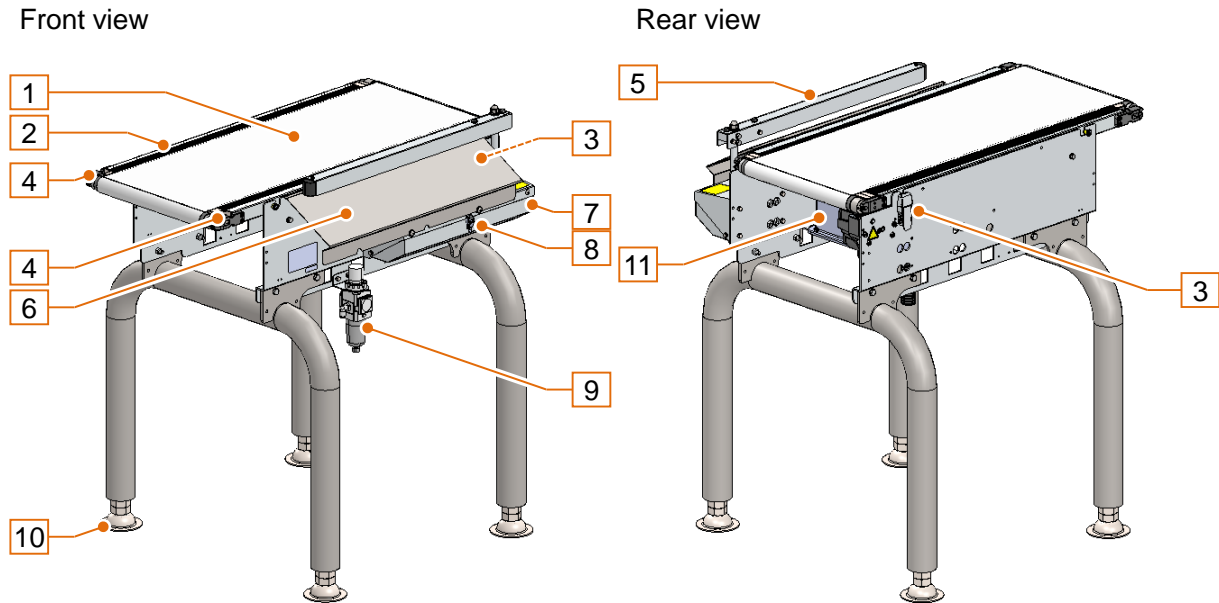

Fig. 3 Overall view (AD-4981-2570)

Table 3 Part names and functions

No.	Name	Function
1	Belt	Conveys products. Can be removed and cleaned.
2	Conveyor base	The pulleys to move the belt and the base to convey products.
3	Draw latches of the conveyor	To firmly attach the conveyor base to the rejector, there is one latch on the front side and one on the back side of the rejector.
4	Belt tension adjusting screws	To adjust the tension of the belt, there is one screw on the front side and one on the back side of the rejector. Belt meandering can be also adjusted by adjusting the screws.
5	Arm	Operates according to external signals for rejecting products away from the conveying direction.
6	Chute plate	When a product is rejected, it slides down on the surface of the plate.
7	Cylinder case	An air cylinder for moving the arm is built in. The speed controller attached to the air cylinder can adjust the speed of the air cylinder.
8	Draw latch of the case	Opens and closes the cylinder case.
9	Filter regulator	Adjusts the air pressure supplied to the air cylinder.
10	Adjustable feet	The height of the conveyor can be adjusted by turning the height adjustment nuts.
11	Control box	Contains a circuit board that controls the motor and a solenoid valve that controls the air cylinder.

3-2 Cables

This rejector has four cables that are routed externally.

The cables are routed from the bottom of the rejector through the corrugated tube.

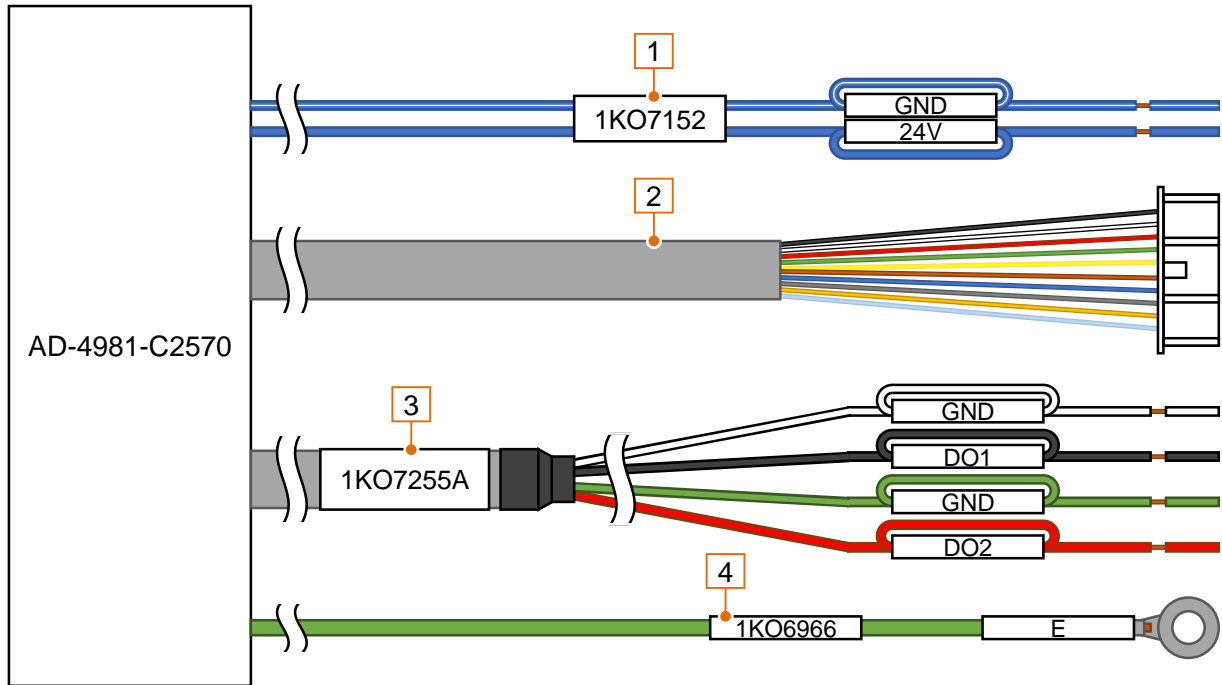

Fig. 4 Appearances of cable tips

Table 4 Cable name and function

No.	Name	Function
1	Motor power cable (1KO7152)	Connects the external power supply to the motor control board of the rejector.
2	Motor control cable (1KO4338)	Connects the external motor control signal source to the motor control board of the rejector.
3	Screening signal cable (1KO7255A)	Connects the external general-purpose output signal source to the solenoid valve of the rejector.
4	Ground cable (1KO6966)	Connects the ground of the inspection system to the main unit of the rejector.

3-3 Warning labels

Front view

Rear view

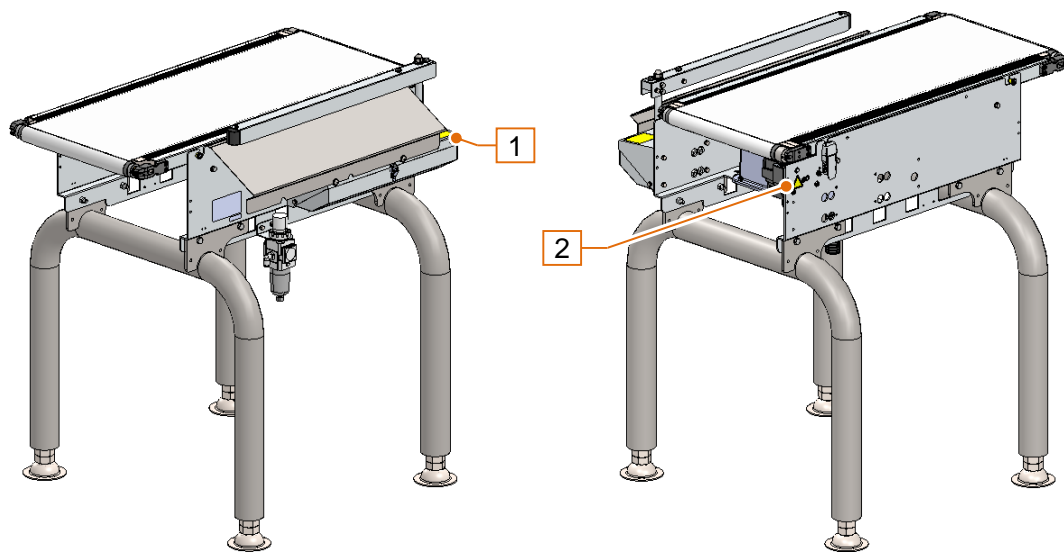

Fig. 5 Positions of the warning labels

Table 5 Warning labels

No.	Label	Meaning of the label
1		Be careful not to get caught in the flipper arm.
2		Be careful not to get caught in the rotating part of the motor gear.

4. Assembly

4-1 Main unit

Caution:

Assembly work should be done by two or more people.

1. Using a 10 mm wrench, attach the base unit to the rejector main unit with the mounting screws for the base unit.

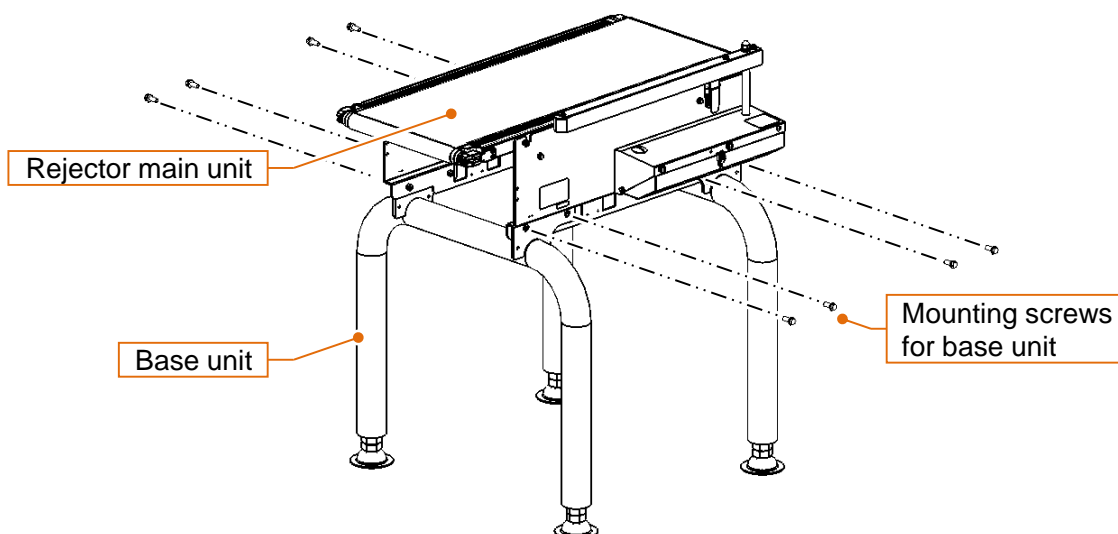

Fig. 6 Attaching the rejector main unit

2. Using a 7 mm wrench, attach the filter regulator bracket to the rejector main unit with the filter regulator bracket mounting screws. In the figure below, it is attached to the front side of the rejector, but it can also be attached to the rear side.

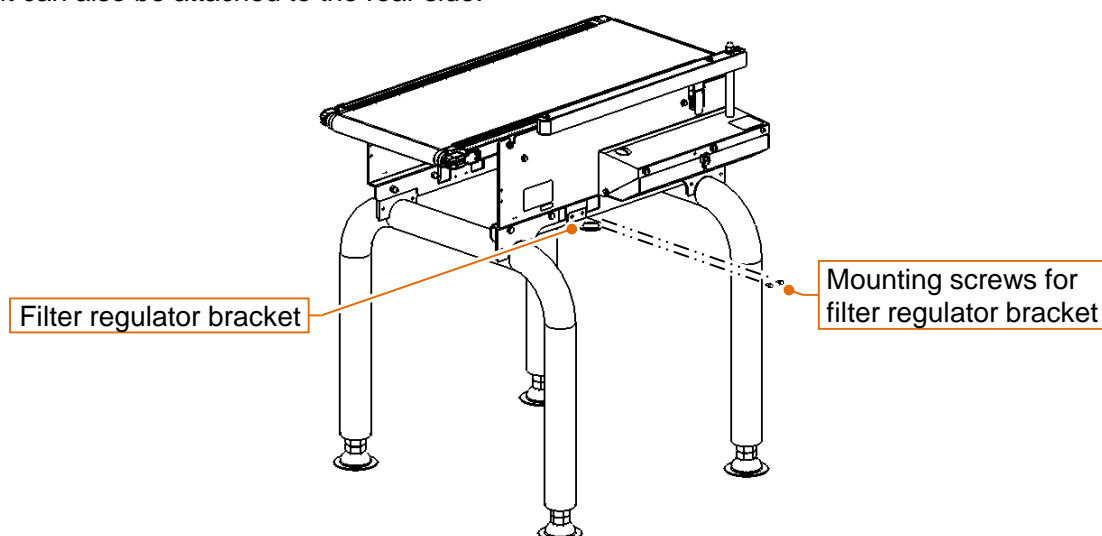

Fig. 7 Attaching the filter regulator bracket

3. Attach the filter regulator to the filter regulator bracket with the filter regulator nut.

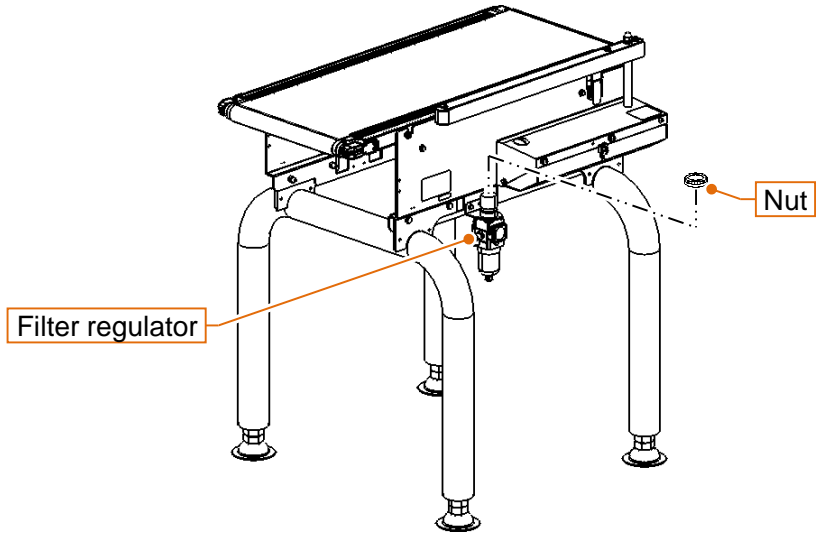

Fig. 8 Attaching the filter regulator

4. Connect the air tube (longer one) of the control box to the filter regulator.



Fig. 9 Filter regulator piping

5. Insert the chute plate into the chute plate retainers (A).
Next, place the chute plate into the grooves of the plate holders (B).

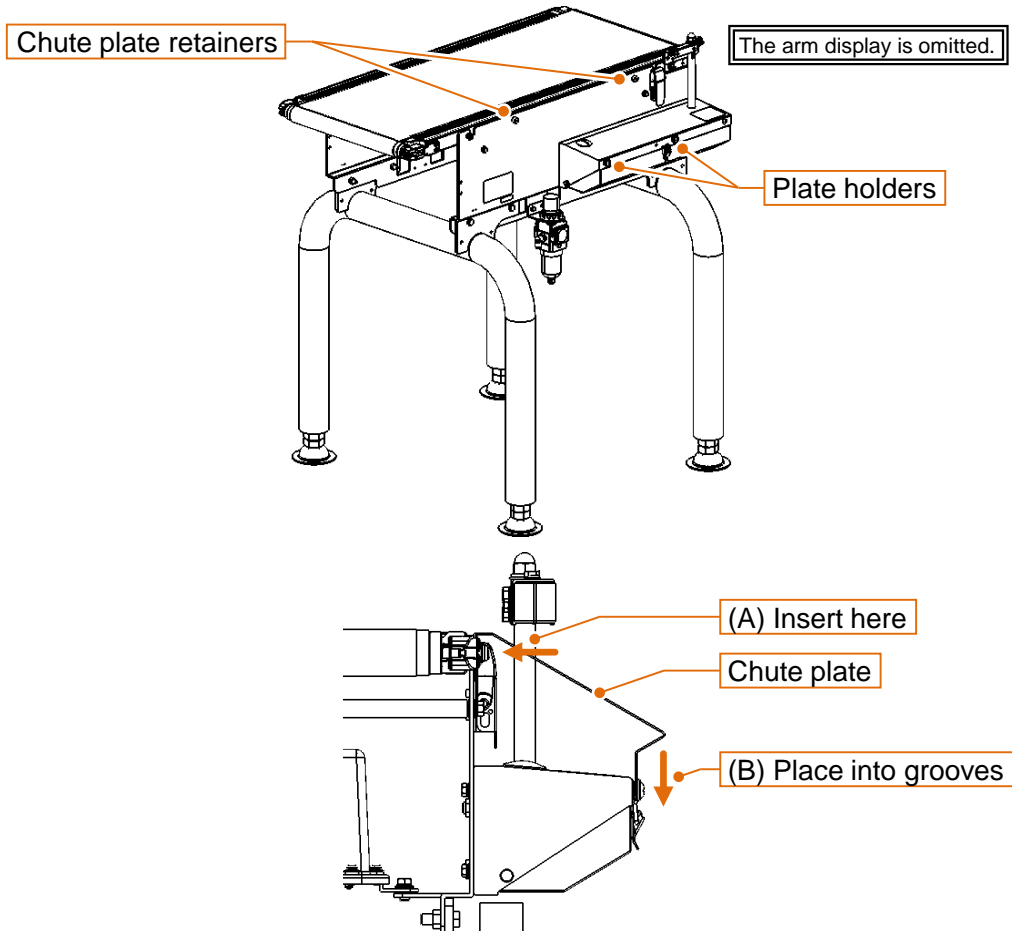

Fig. 10 Attaching the chute plate

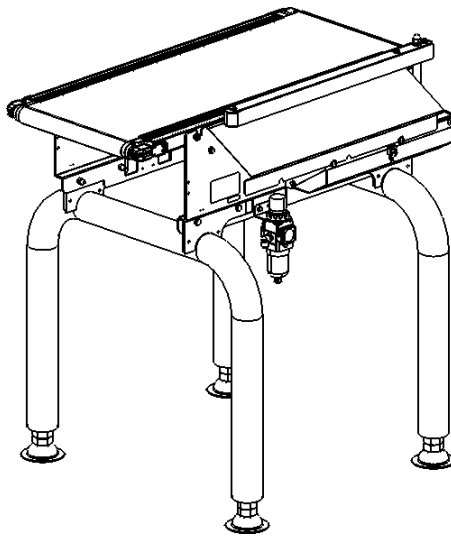

Fig. 11 Completed assembly of the main unit

4-2 Flipper arm (sold separately)

Caution:

To prevent injury or equipment failure during work, cut off the power supply to the inspection system (X-ray inspection system, checkweigher, or metal detector) connected to the rejector.

First, prepare to install the flipper arm (sold separately) on the rejector.

1. Lift the chute plate from the plate holders (A).

Then remove the chute plate from the chute retainers (B).

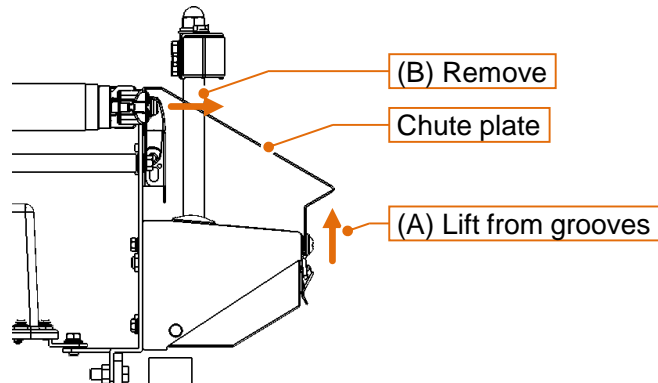

Fig. 12 Removing the chute plate

2. Release the draw latches of the conveyor.

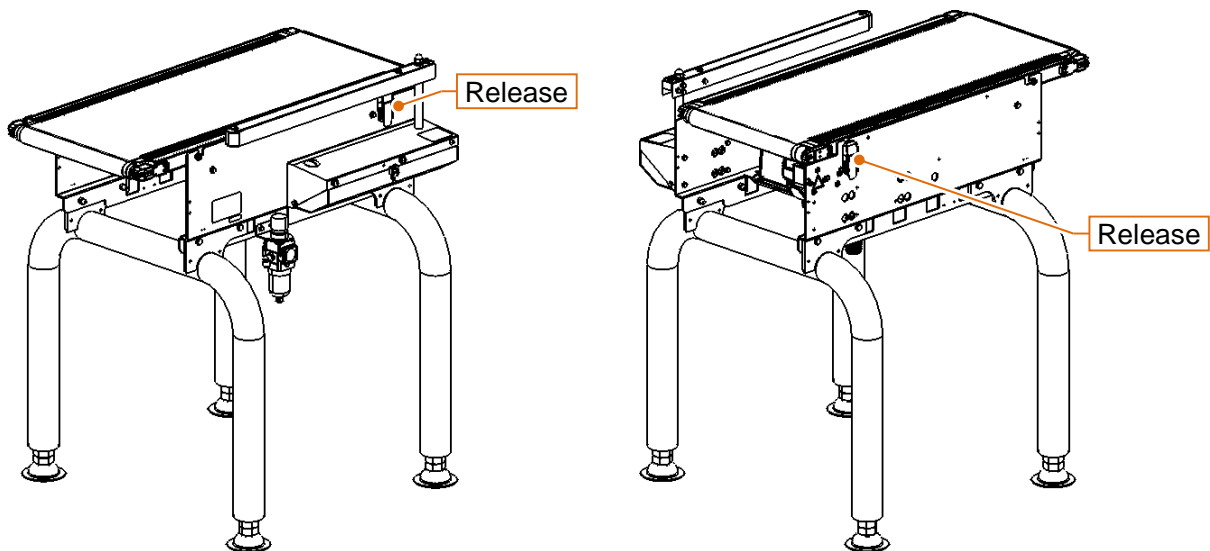

Fig. 13 Releasing the draw latches of the conveyor

- Lift the conveyor draw latch side of the conveyor base (A).
Next, slide the conveyor base towards the side of the conveyor draw latches (B).
Then lift the conveyor base and remove it from the rejector main unit (C).

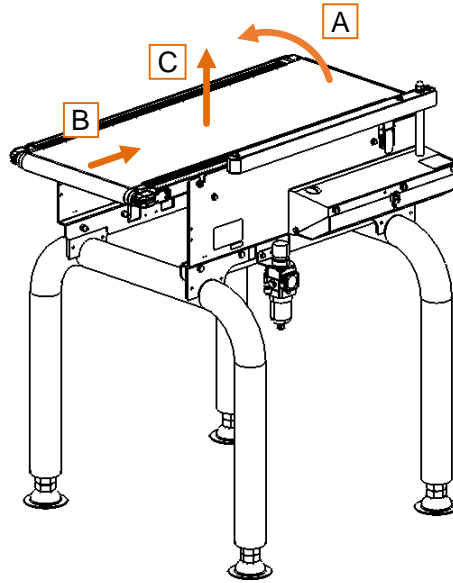

Fig. 14 Removing the conveyor base

- Using a #2 Phillips screwdriver and adjustable wrench, attach the chute plate retainers to the rejector with the flat head screws.

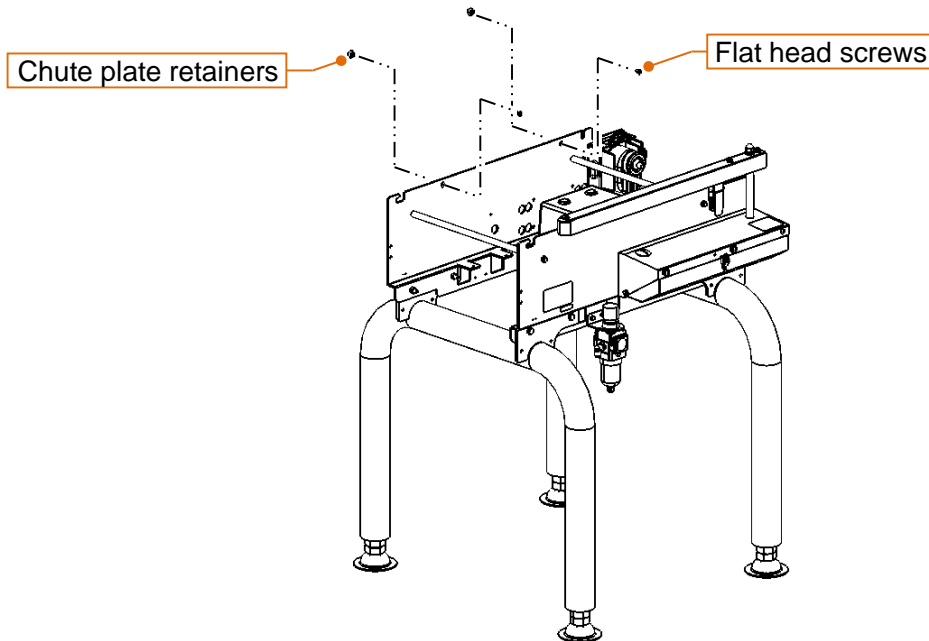

Fig. 15 Attaching the chute plate retainer

Next, attach the arm to the shaft side of the flipper arm (sold separately) and then attach it to the rejector.

- Using 7 mm, 8 mm, and 13 mm wrenches, attach the arm to the shaft with the hexagon head screws, cap nut, plain washer, and spring washer.

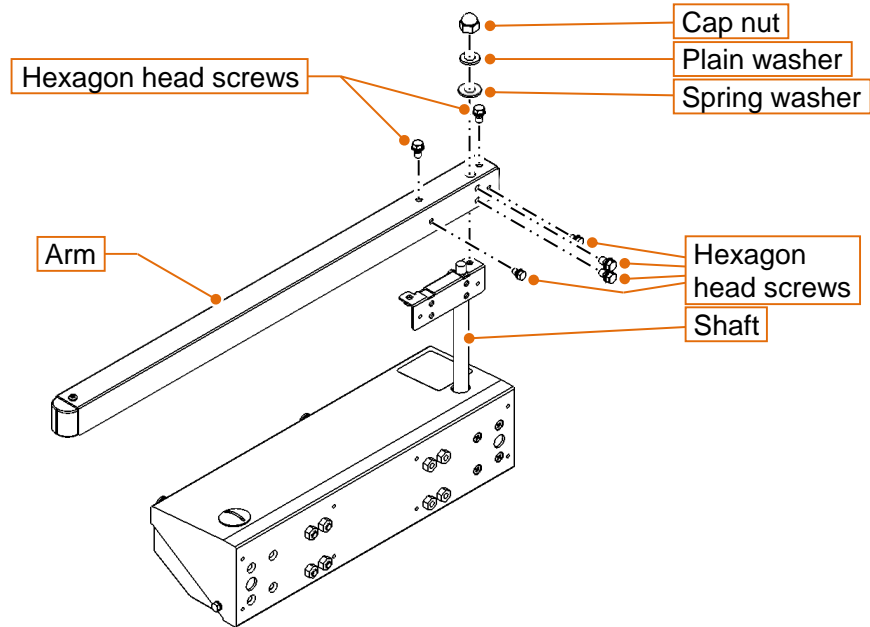

Fig. 16 Attaching the arm

- Pass the air tubes of the unit assembled in **step 5** through the air piping hole in the side plate of the rejector unit. Using a 7 mm wrench, attach the unit assembled in **step 5** to the rejector with the hexagon head screws.

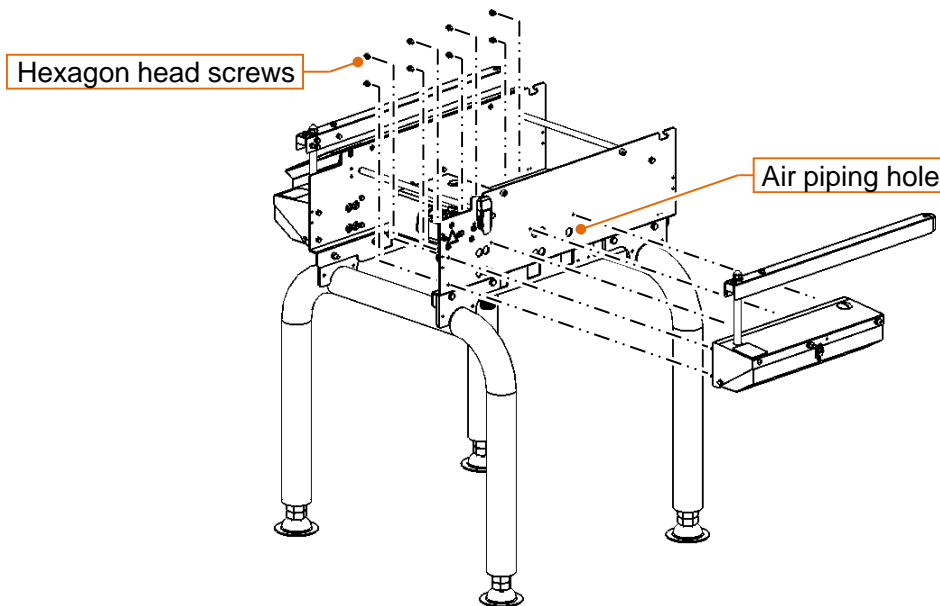

Fig. 17 Attaching the unit assembled in step 5

7. Using a #2 Phillips screwdriver, remove the pan head screws of the control box to remove the control box case (A).
Next, using a #0 Phillips screwdriver, remove the pan head screws to remove the blanking plate from the mounting position of the solenoid valve (B).
Then attach the solenoid valve to the control box (C).

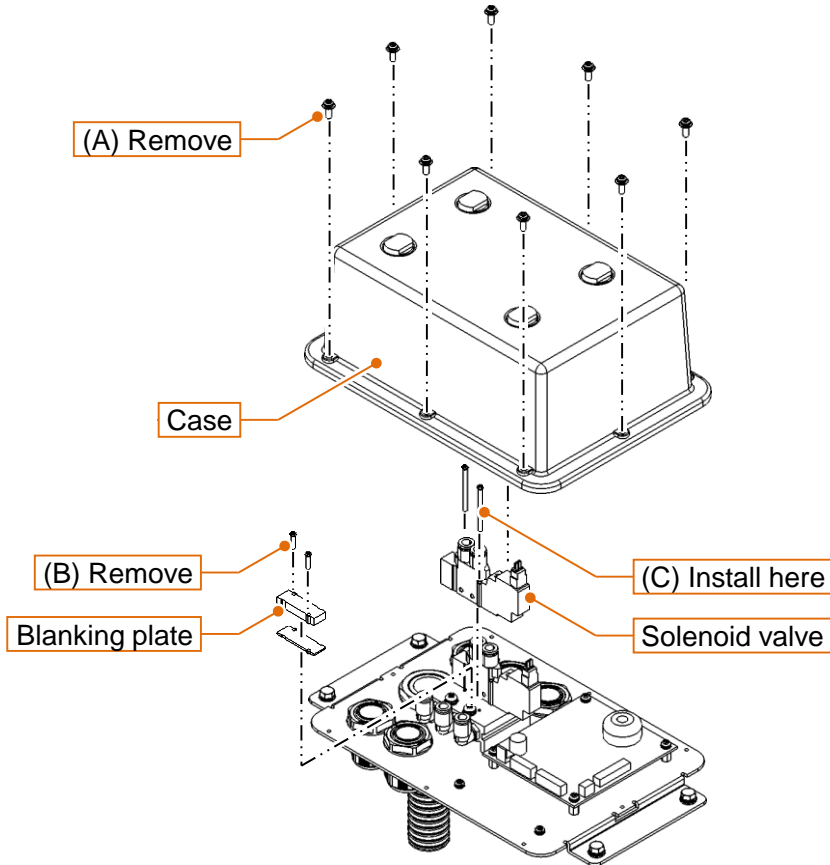

Fig. 18 Attaching the solenoid valve

8. Connect the connector of the solenoid valve installed in [step 7](#) to the connector of the screening signal cable (1KO7255A).

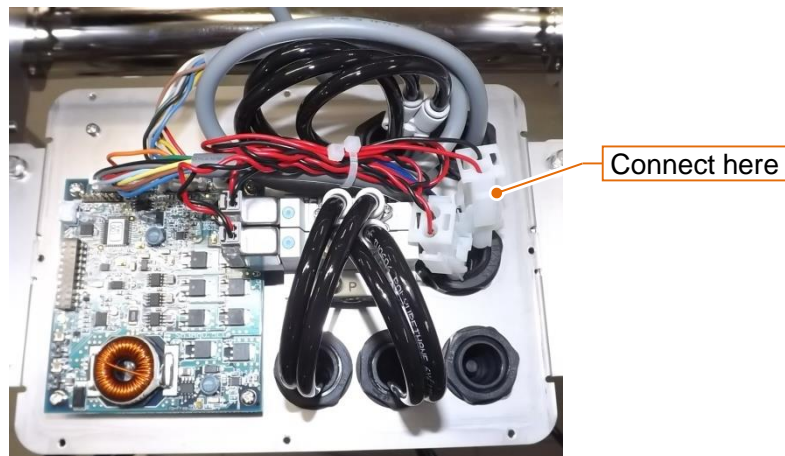

Fig. 19 Connecting the solenoid valve connector

9. Pass the air tubes that were passed through the hole in **step 6** through the cable gland of the control box (A).

Next, connect the air tubes to the solenoid valve installed in **step 7** with the label notation of each air tube matching the notation on the solenoid valve (B).

Then tighten the cable gland.

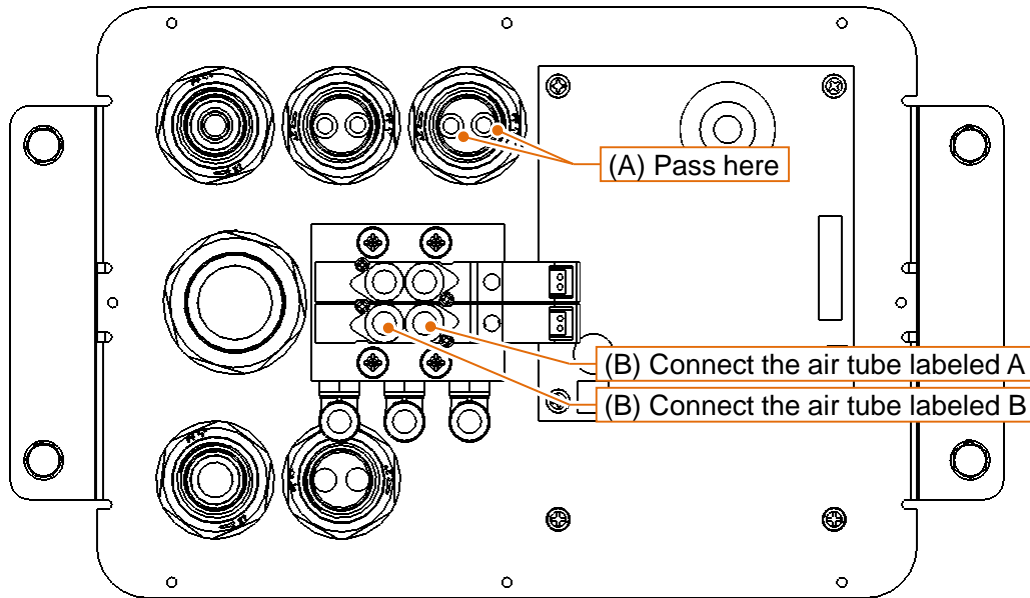

Fig. 20 Solenoid valve air piping

10. Using a #2 Phillips screwdriver, reattach the control box case with the pan head screws removed in **step 7**.
11. Reattach the conveyor base removed in **step 3**.
12. Close the draw latches released in **step 2** to resecure the conveyor base.
13. Reattach the chute plate removed in **step 1**.

Also attach the chute plate for the flipper arm (sold separately).

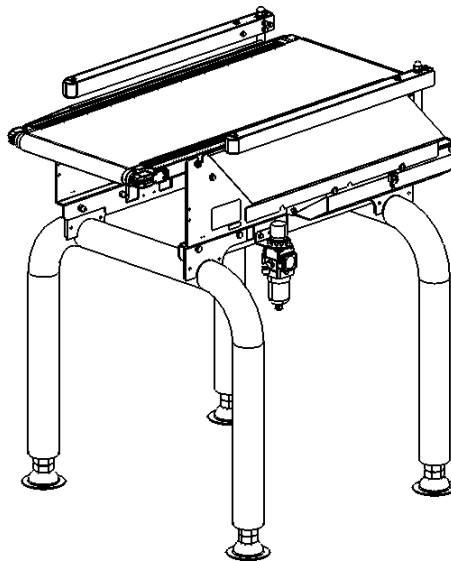

Fig. 21 Completed assembly of the flipper arm (sold separately)

4-3 Reject confirmation unit (sold separately)

Caution:

- To prevent injury or equipment failure during work, cut off the power supply to the inspection system (X-ray inspection system, checkweigher, or metal detector) connected to the rejector.
 - In this section, the three-direction reject confirmation unit is described.
1. Using a 7 mm wrench, attach the rejection confirmation unit to the rejector with the hexagon head screws. By loosening the hexagon socket set screws using a 2 mm hexagon pin wrench, the height of the sensor and reflector can be adjusted.

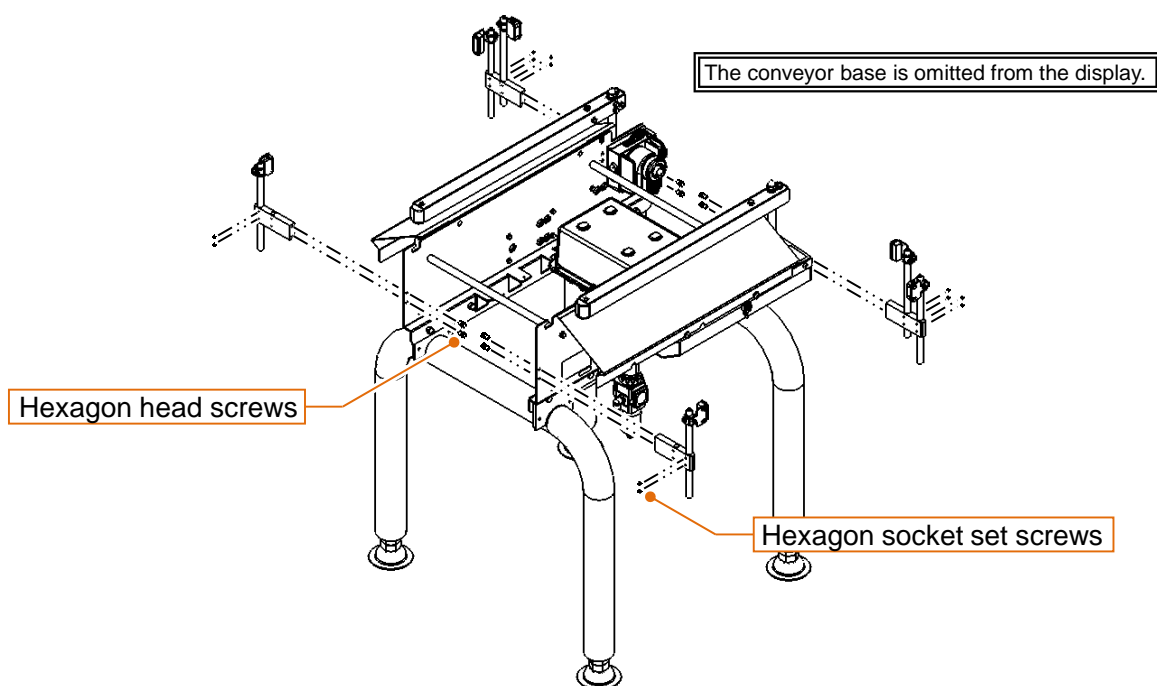

Fig. 22 Attaching the rejection confirmation unit

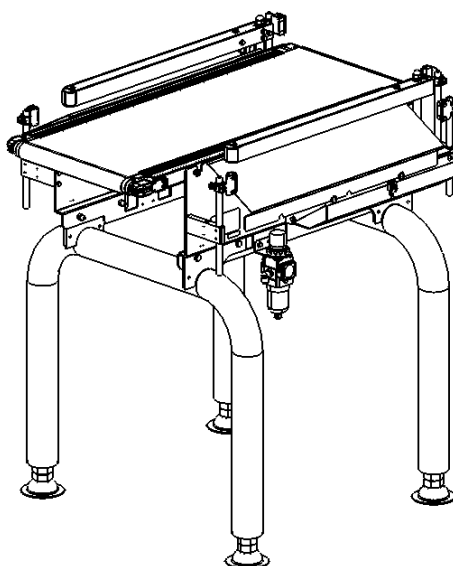

Fig. 23 Completed assembly of the rejection confirmation unit

4-4 Power supply unit (sold separately)

Caution:

To prevent injury or equipment failure during work, cut off the power supply to the inspection system (X-ray inspection system, checkweigher, or metal detector) connected to the rejector.

1. Lift the chute plate from the plate holders (A).
Then remove the chute plate from the chute plate retainers (B).

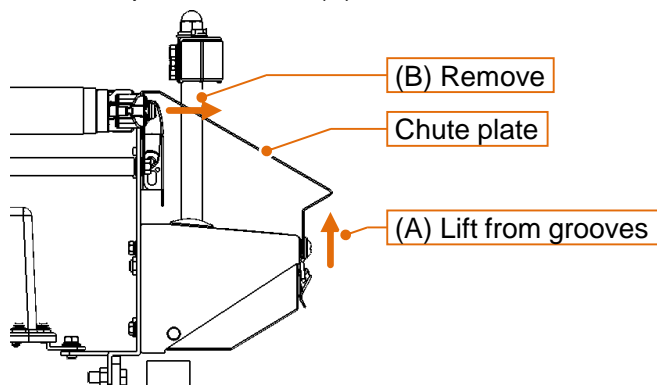

Fig. 24 Removing the chute plate

2. Release the draw latches of the conveyor.

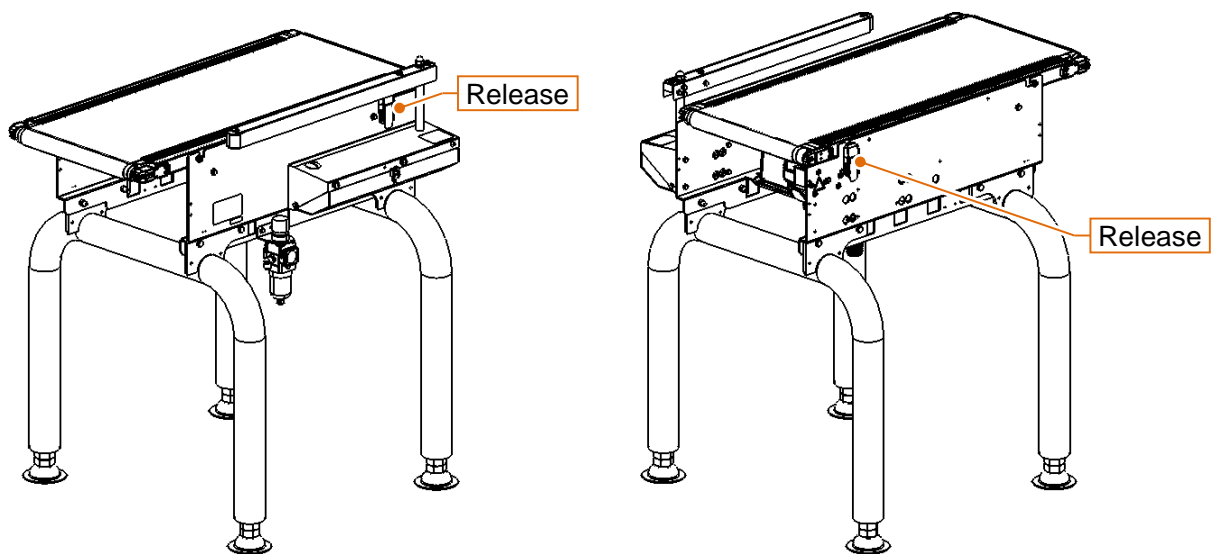

Fig. 25 Releasing the draw latches of the conveyor

- Lift the conveyor draw latch side of the conveyor base (A).
Next, slide the conveyor base towards the side of the conveyor draw latches (B).
Then lift the conveyor base and remove it from the rejector main unit (C).

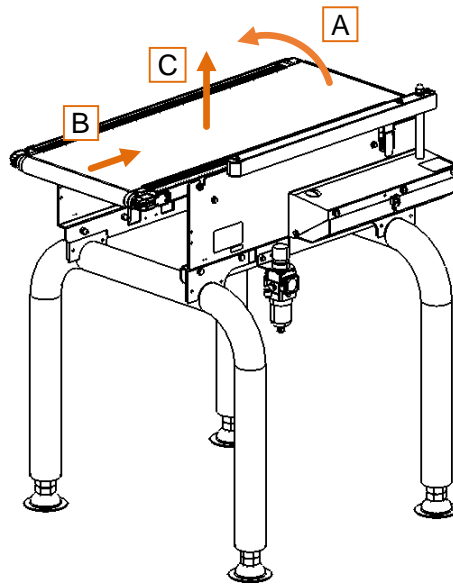

Fig. 26 Removing the conveyor base

- Using an 8 mm wrench, attach the power supply unit and plastic bushings to the rejector with the hexagon head screws. Attach so that the 24 V cable (1KO6714) is on the control box side.

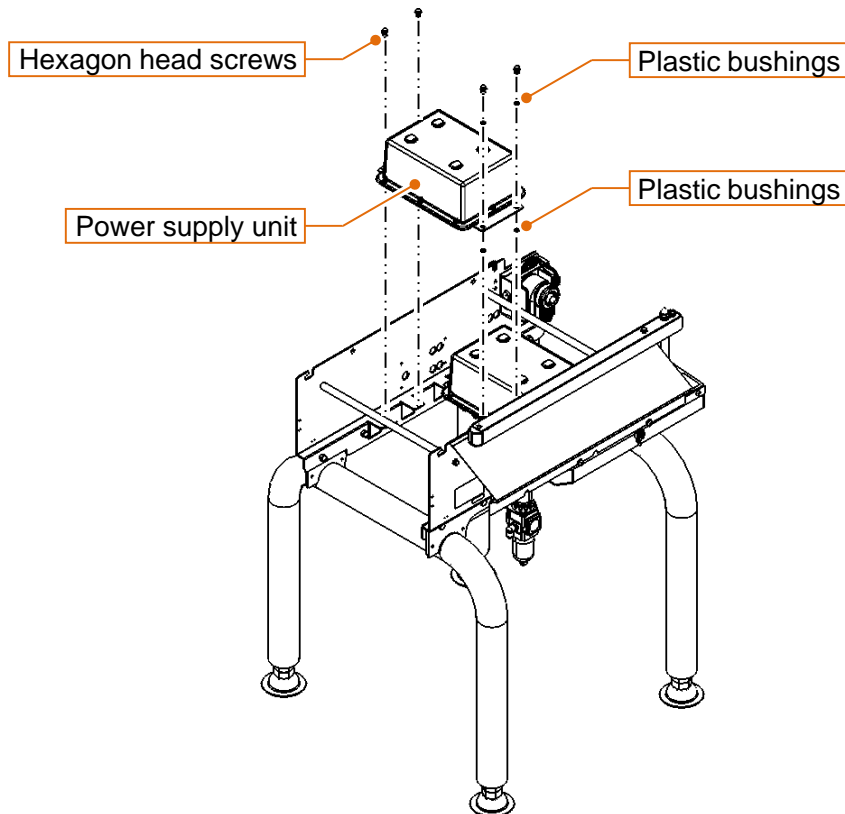

Fig. 27 Attaching the power supply unit and plastic bushings

5. Using a #2 Phillips screwdriver, remove the pan head screws for the control box to remove the case from the control box.

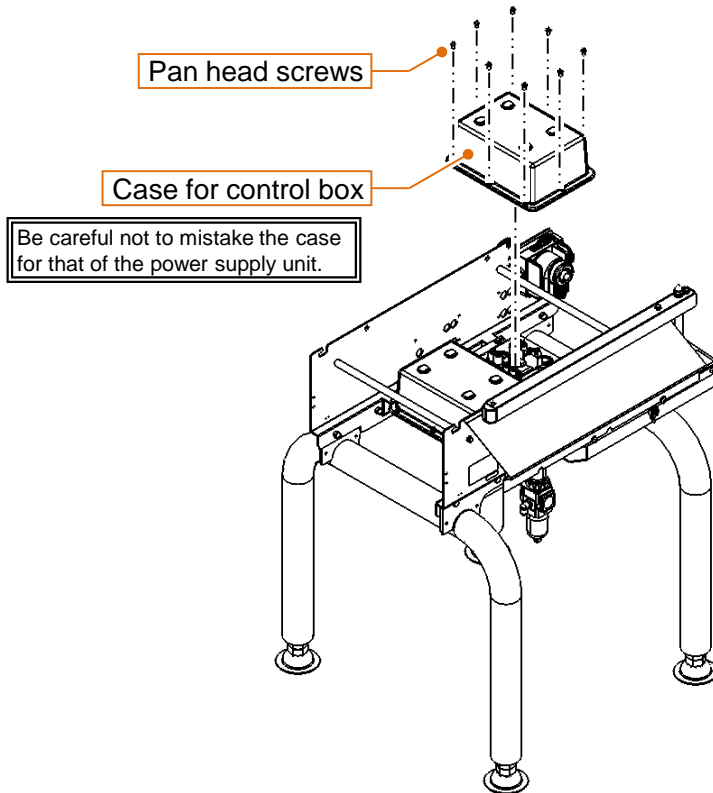

Fig. 28 Removing the case from the control box

6. Pass the 24 V cable (1KO6714) of the power supply unit through the cable gland (A). Next, remove the 24 V cable (1KO7152) connected to the connector shown below, and then connect the connector of the 24 V cable (1KO6714) (B). Then tighten the cable gland.

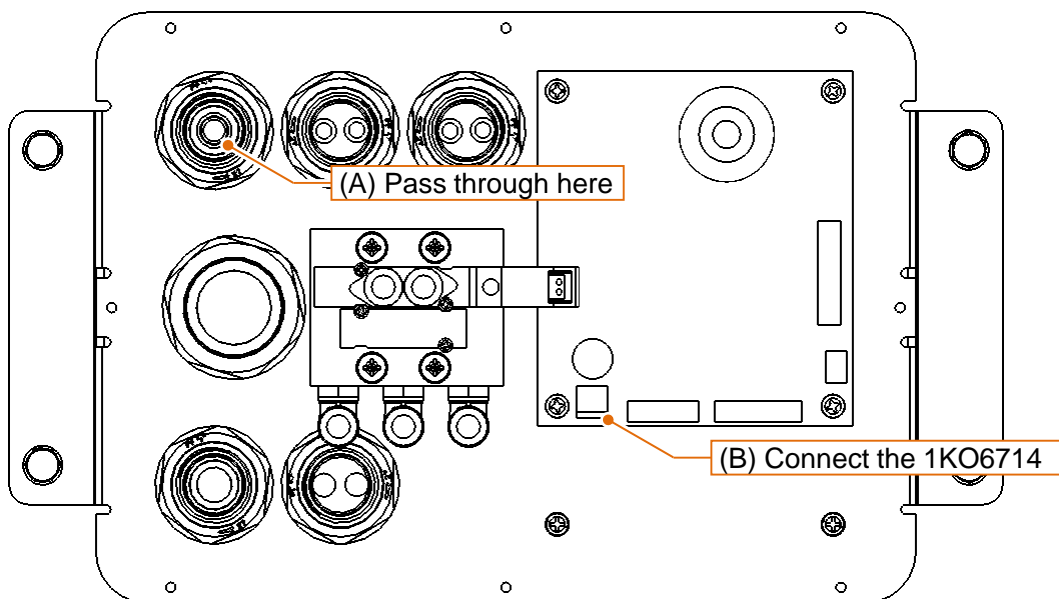

Fig. 29 Connecting 24 V cable (1KO6714)

7. Using a #2 Phillips screwdriver, reattach the control box case with the pan screws removed in **step 5**.
8. Reattach the conveyor base removed in **step 3**.
9. Fasten the draw latches released in **step 2** and resecure the conveyor base.
10. Reattach the chute plate removed in **step 1**.

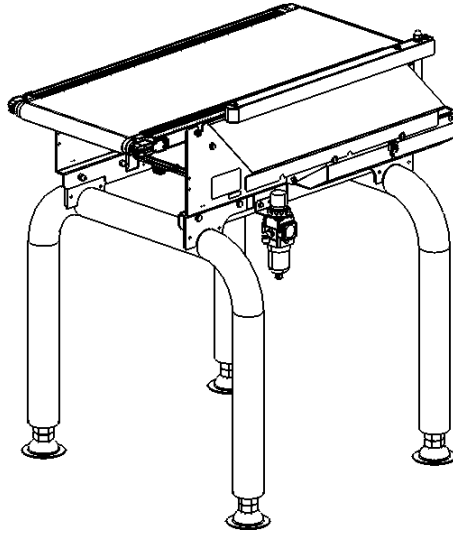

Fig. 30 Completed assembly of the power supply unit

4-5 Flipper rejector arm plate (sold separately)

Caution:

To prevent injury or equipment failure during work, cut off the power supply to the inspection system (X-ray inspection system, checkweigher, or metal detector) connected to the rejector.

1. Using a 7 mm, 8 mm, and 13 mm wrench, remove the hexagon head screws, cap nut, plain washer, spring washer, and arm from the shaft.

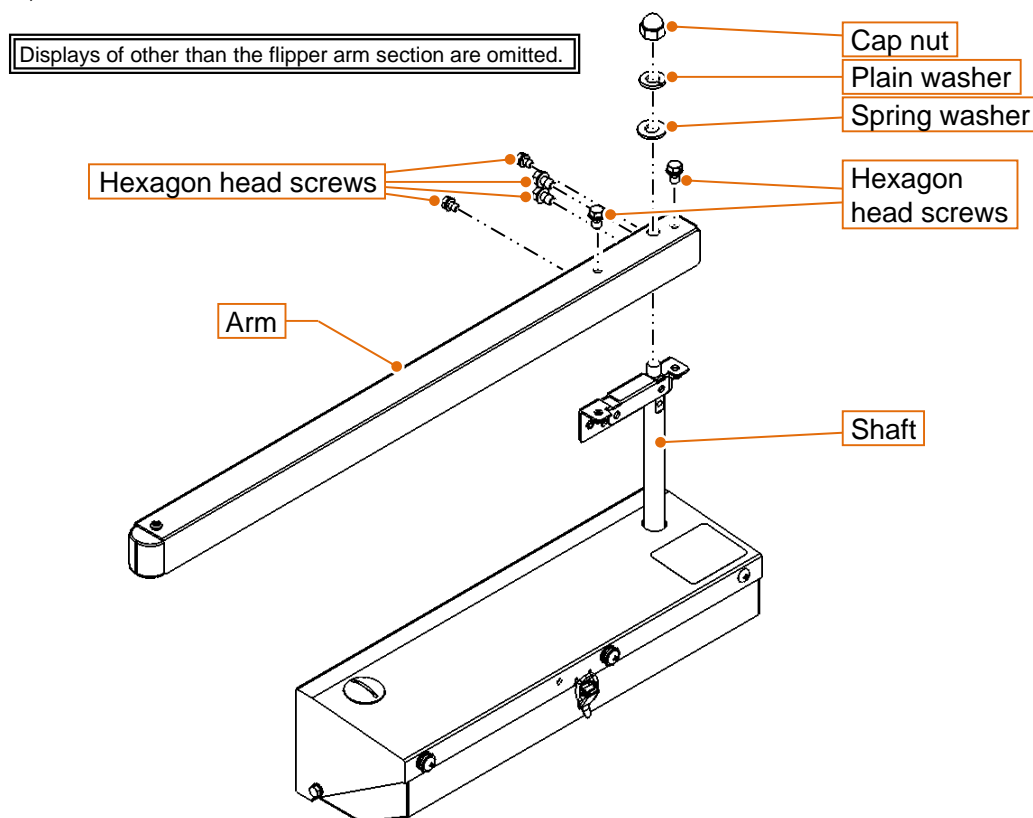

Fig. 31 Removing the arm

- Using a #2 Phillips screwdriver, assemble the flipper rejector arm plate.

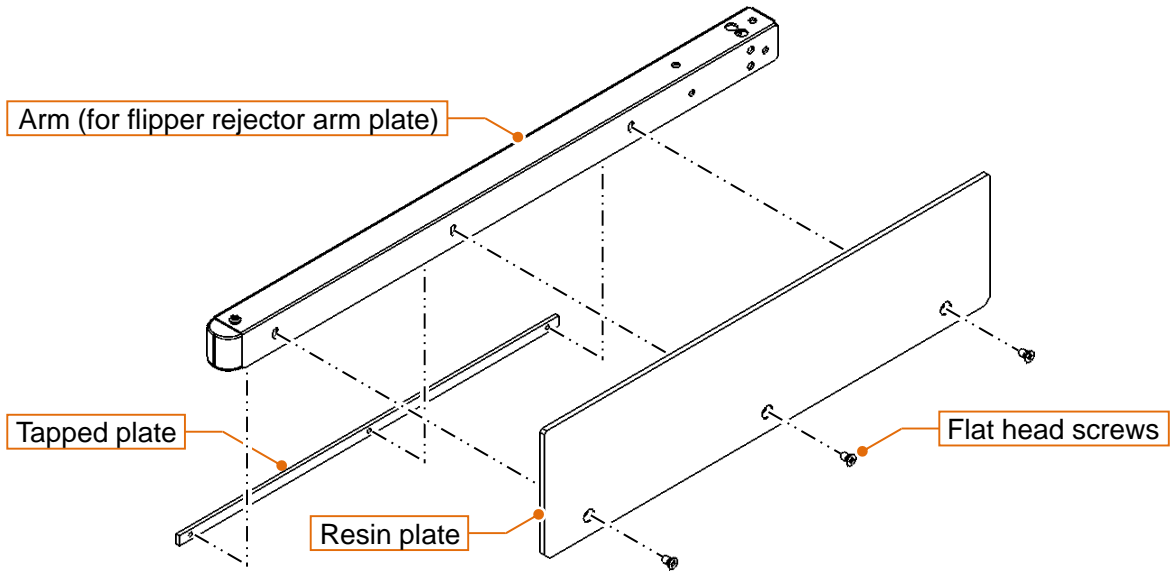

Fig. 32 Assembling the flipper rejector arm plate

- Using a 7 mm, 8 mm, and 13 mm wrench, attach the assembled flipper rejector arm plate to the shaft.

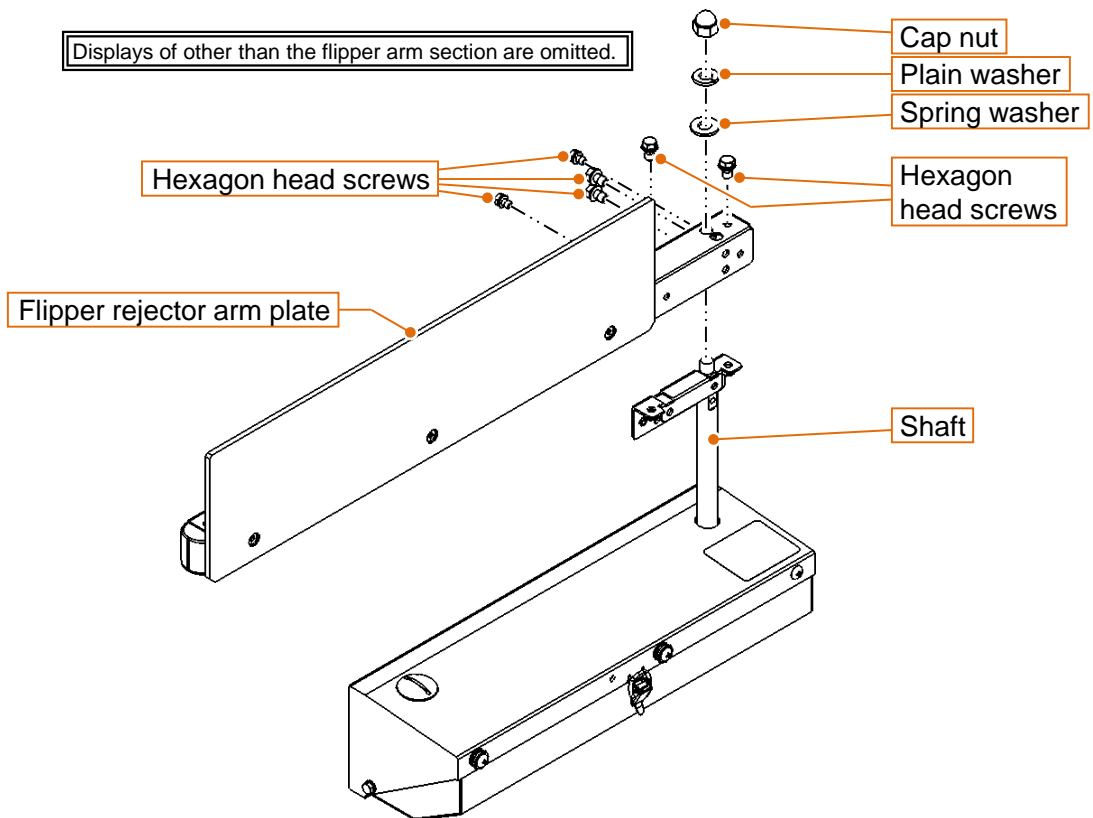

Fig. 33 Attaching the flipper rejector arm plate

5. Installation

1. Install the rejector next to the unit (X-ray inspection system, checkweigher, or metal detector) it will be connected to.
2. The arrow indicates the direction in which products are conveyed. When installing, pay attention to the conveying direction and the orientation of the rejector.

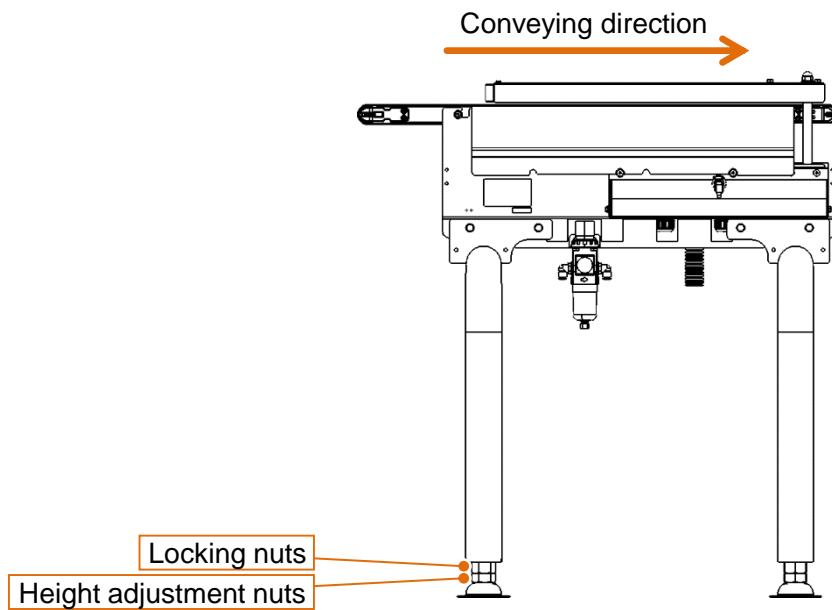

Fig. 34 Installation

3. Using a 30 mm wrench, adjust the conveyor height with the height adjustment nuts.
4. Using a 30 mm wrench, secure the adjustable feet with the locking nuts.

6. Connection

6-1 Connecting to the AD-4991 series

Caution:

To prevent injury or equipment failure during work, cut off the power supply to the AD-4991 series.

1. Remove the rear cover of the AD-4991 series.

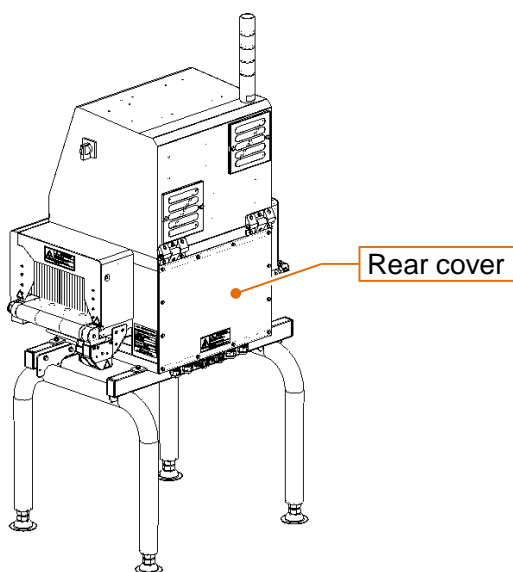

Fig. 35 Removing the rear cover (AD-4991 series)

2. Pass the motor power cable (1KO7152), motor control cable (1KO4338), screening signal cable (1KO7255A), and ground cable (1KO6966) of the AD-4981-2570 through the cable gland of the AD-4991 series.

Keep the plug removed from the cable gland in a safe place.

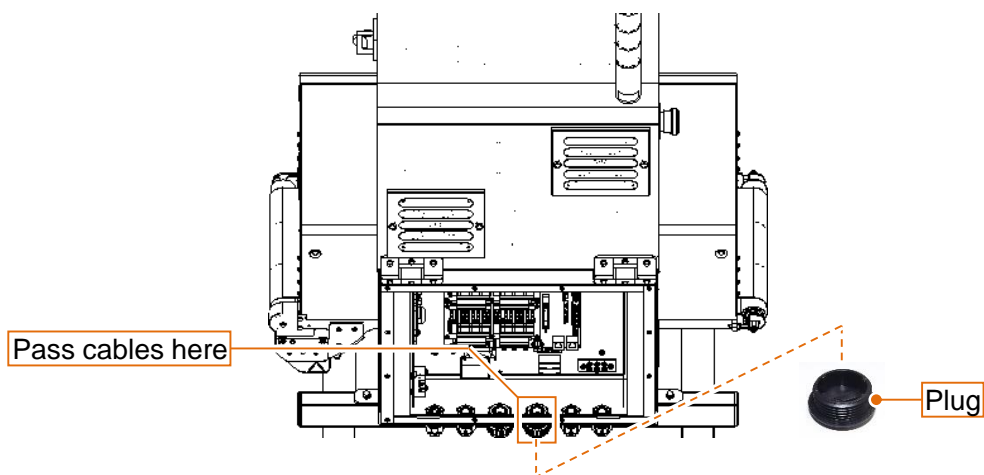

Fig. 36 Cable gland (AD-4991 series)

3. Connect the motor power cable (1KO7152) that was passed through in **step 2** to the connector shown below.

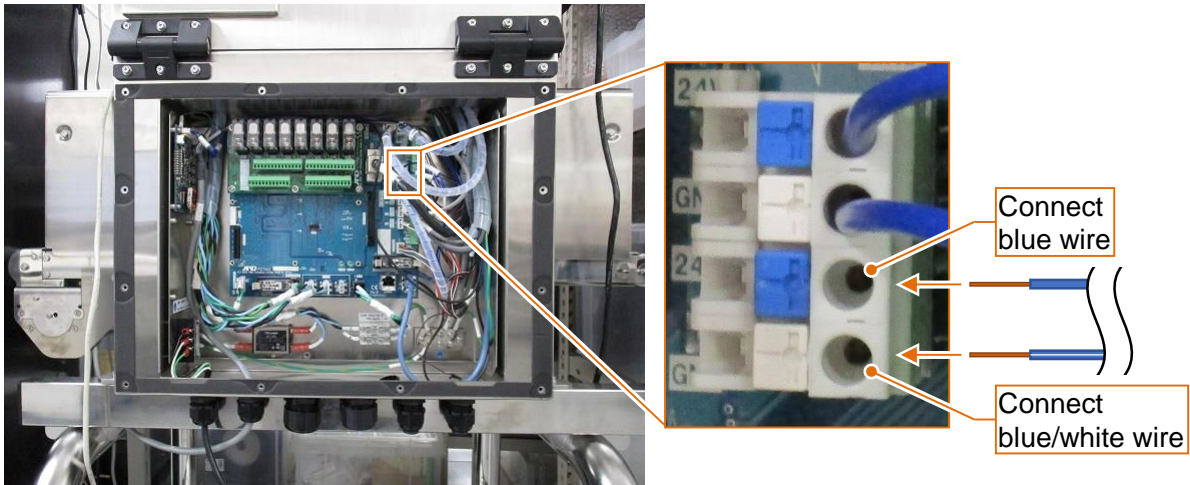

Fig. 37 Connecting the motor power cable

4. Connect the motor control cable (1KO4338) passed in **step 2** to the connector shown below.

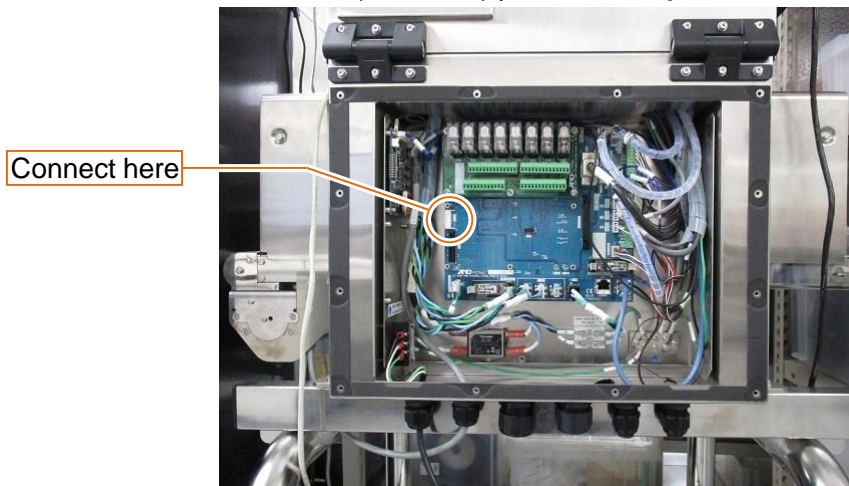

Fig. 38 Connecting the motor control cable

- Remove the connector shown below and connect the screening signal cable (1KO7255A) passed in **step 2** and the supplied 24 V crossover cable.

The figure below shows an example of connection for rejection operation using DO1 and DO2 with a three-direction rejector.

For a two-direction rejector, insulate unused terminals of the screening signal cable and 24 V crossover cable by wrapping them with tape, etc. so that the main board is not shorted (see the dashed line in figure below).

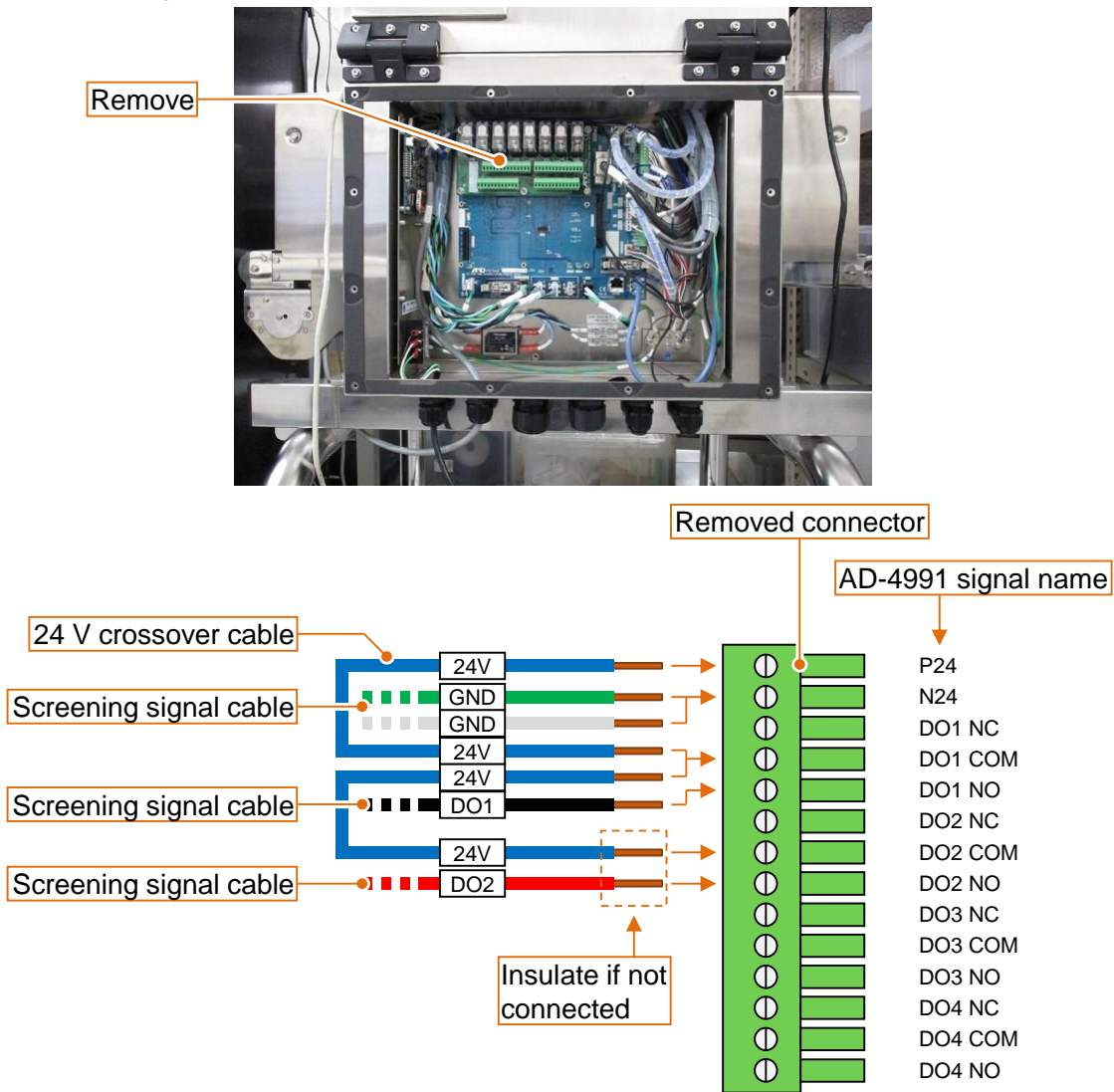

Fig. 39 Connecting the screening signal cable and 24 V crossover cable

- Reattach the connector removed in **step 5**.

7. Pass the corrugated tube through the cable gland, and then tighten the sealing nut loosened in [step 2](#).



Fig. 40 Tightening the sealing nut

8. Reattach the rear cover removed in [step 1](#).
9. Start supplying power to the AD-4991 series, and set the following items as necessary.
- Administrator settings (use of the rejector)
 - Belt settings (belt speed adjustment, error check)
 - Product settings (belt speed of rejector, DO map, DO behavior)
 - DI settings (DI setting, reject confirmation, reject timing)

6-2 Connecting to the AD-4976-H series

Caution:

To prevent injury or equipment failure during work, cut off the power supply to the AD-4976-H series.

1. Lift the chute plate from the plate holders (A).
Then remove the chute plate from the chute plate retainers (B).

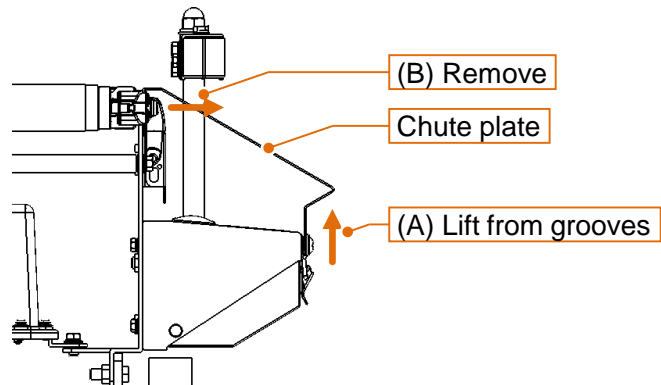

Fig. 41 Removing the chute plate

2. Release the draw latches of the conveyor.

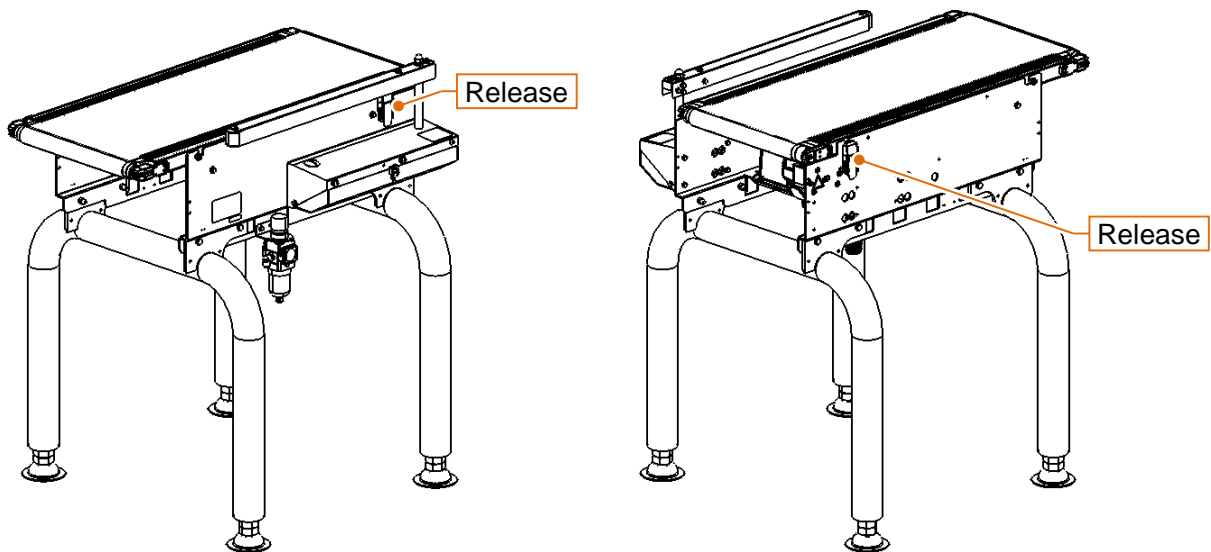

Fig. 42 Releasing the draw latches of the conveyor

- Lift the conveyor draw latch side of the conveyor base (A).
Next, slide the conveyor base towards the side of the conveyor draw latches (B).
Then lift the conveyor base and remove it from the rejector main unit (C).

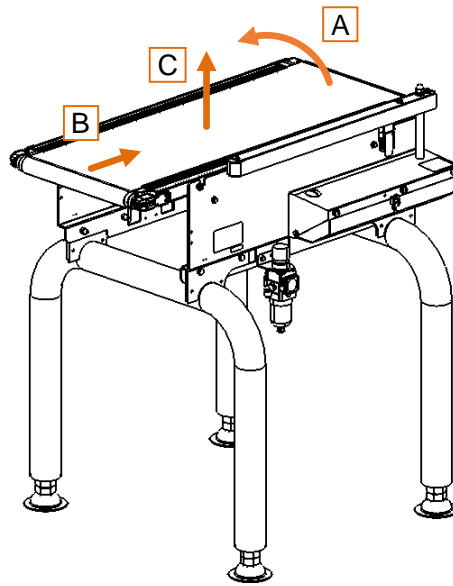

Fig. 43 Removing the conveyor base

- Using a #2 Phillips screwdriver, remove the pan head screws for the control box to remove the case from the control box.

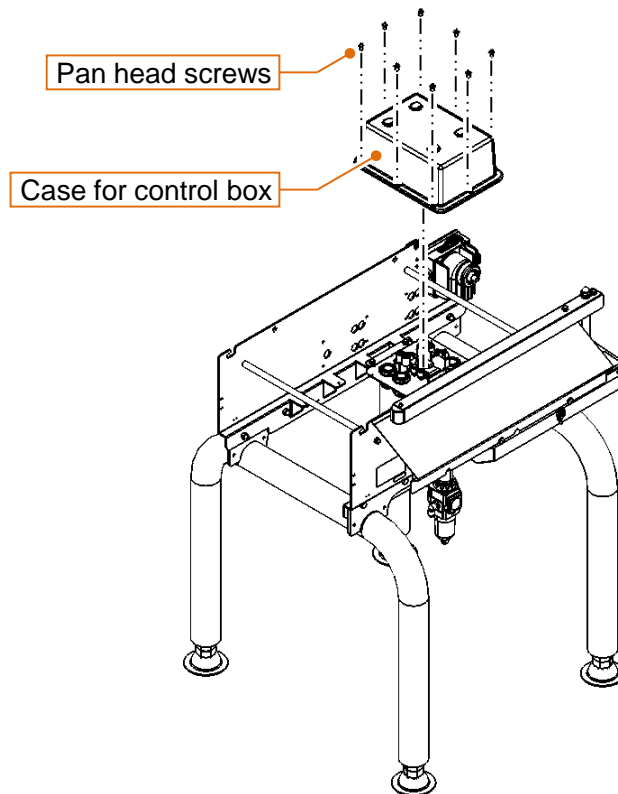

Fig. 44 Removing the case from the control box

- After removing the three cables from the motor control board, use a #2 Phillips screwdriver to remove the four pan screws, then remove the motor control board from the control box (leaving the ground cable attached to the hexagonal spacer).
Unplug the motor cable removed from the motor control board by loosening the cable gland.
Pull the motor power cable and the motor control cable off the cable ground.
Keep the three removed cables in a safe place as they will not be used when connecting to the AD-4976-H series.

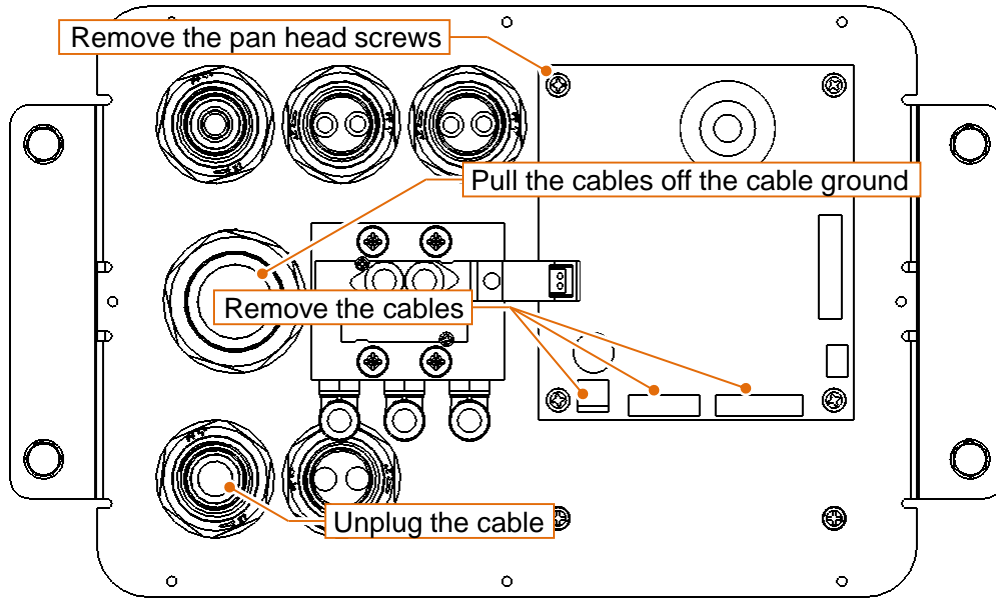

Fig. 45 Removing the motor control board

- Using long-nose pliers, remove the hose clamp from the rejector motor unit.

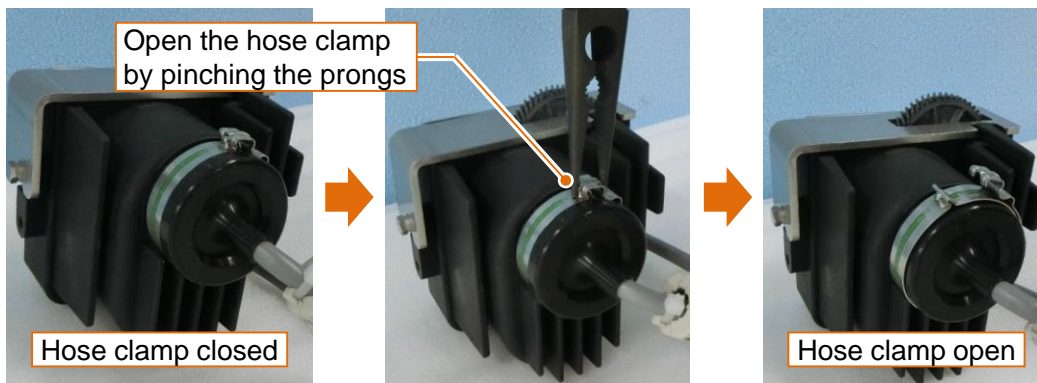

Fig. 46 Removing the hose clamp

7. Remove the motor cable from the connector on the motor unit.
Replace the cable cap, cable cap retainer, and hose clamp from the removed motor cable with the motor cable supplied with the AD-4976-H series.

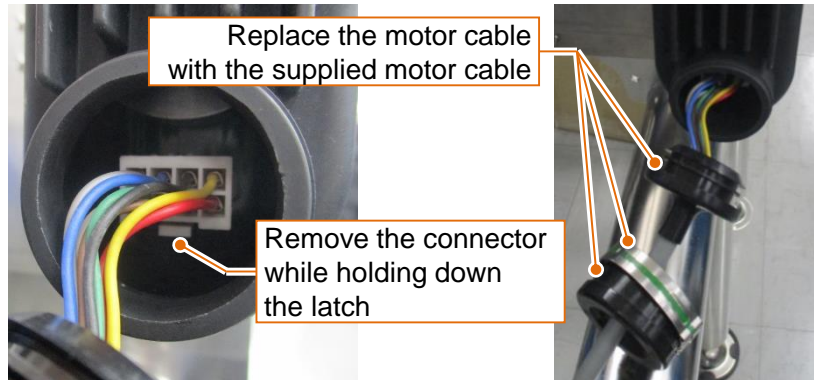

Fig. 47 Removing the motor cable

8. Attach the motor cable supplied with the AD-4976-H series to the motor unit.
Attach the hose clamp in the reverse order of the removal procedure.

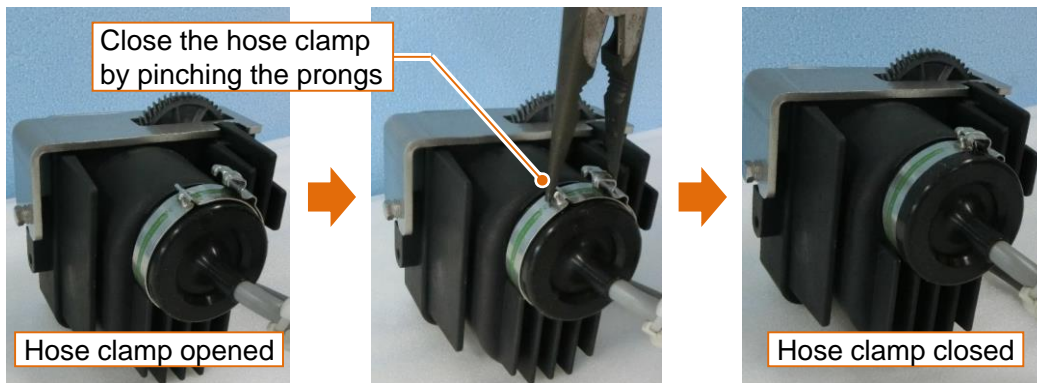

Fig. 48 Attaching the hose clamp

9. Attach the ferrite core (GRFC-9) supplied as an AD-4976-H series accessory to the motor cable attached in [step 8](#) with one turn. Secure the ferrite core in the vicinity of the motor unit using a cable tie.

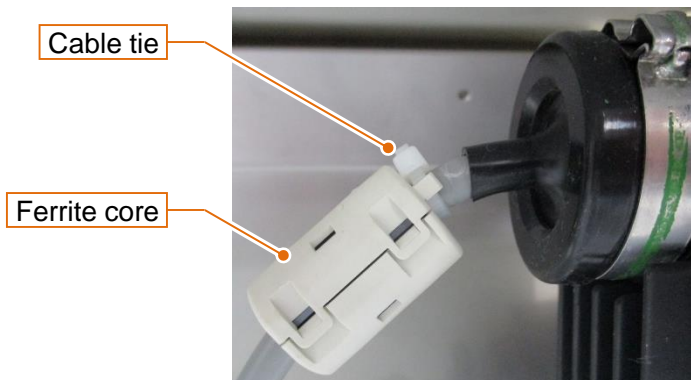

Fig. 49 Attaching the ferrite core (motor cable)

- Using a 7 mm wrench, remove the waterproof hexagon head screws to remove the front and top sensor head covers of the AD-4976-H series.

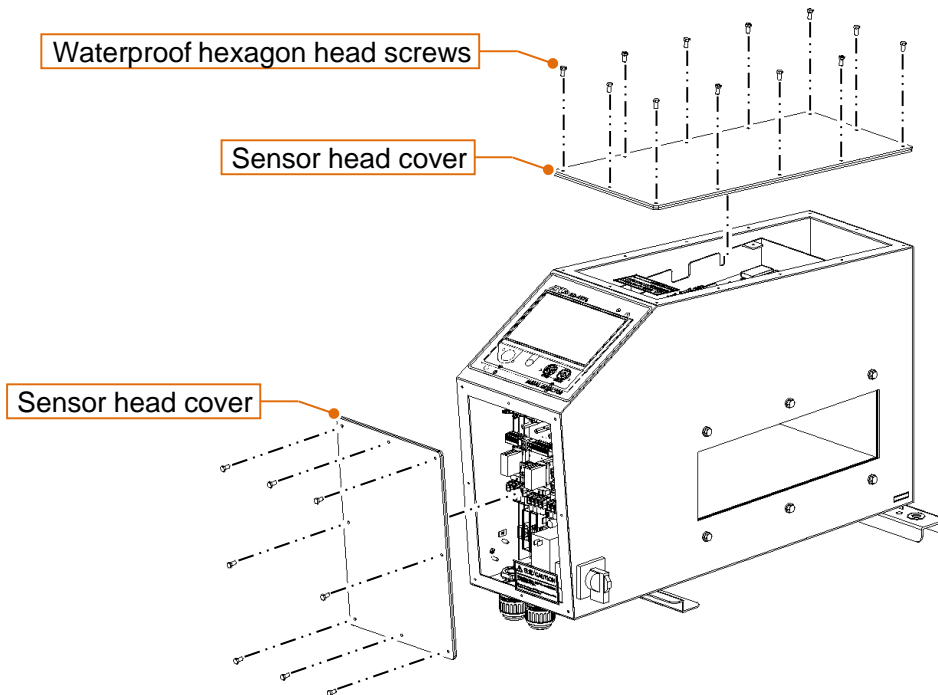

Fig. 50 Removing the sensor head covers

- Pass the motor cable attached to the rejector motor unit in [step 7](#) through the cable gland of the AD-4976-H series.

The seal pin removed from the cable gland is attached to the cable gland from which the motor cable was pulled out in [step 5](#).

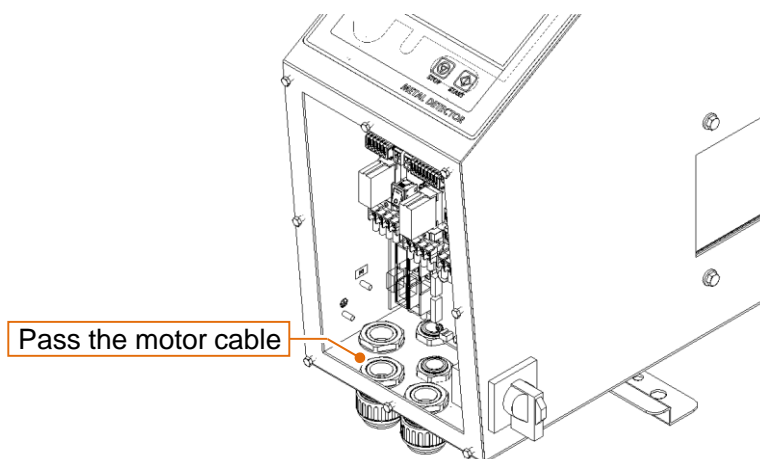

Fig. 51 Cable gland for the motor cable

12. Attach a ferrite core (MRFC-13) to the motor control cable supplied as an AD-4976-H series accessory with two turns, then connect it to the main board (A).
Then, using the cable tie supplied as an AD-4976-H series accessory, secure the ferrite core of the motor control cable to the cable tie fastener (B).
Finally, pass the motor control cable through the front on the inside of the sensor head (C).

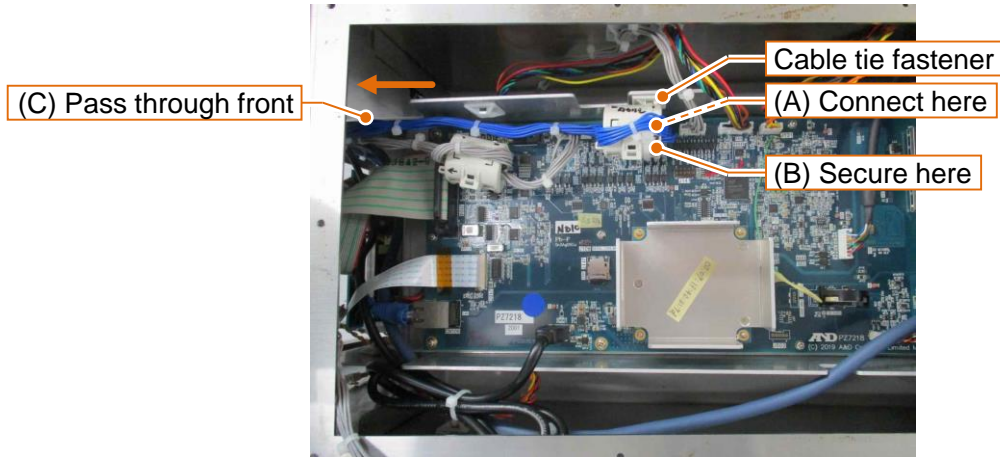

Fig. 52 Connecting the motor control cable

13. Cut the cable tie that binds and secures the M/D P.S. cable to the inside wall of the AD-4976-H series to release the M/D P.S. cable.

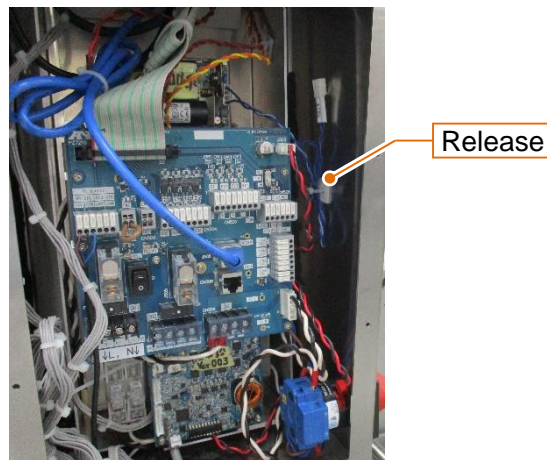

Fig. 53 Releasing the M/D P.S. cable

14. Using a #2 Phillips screwdriver, attach the motor control board removed in [step 5](#) to the AD-4976-H series.

Connect the three cables from [step 11](#), [step 12](#), and [step 13](#) to the motor control board.

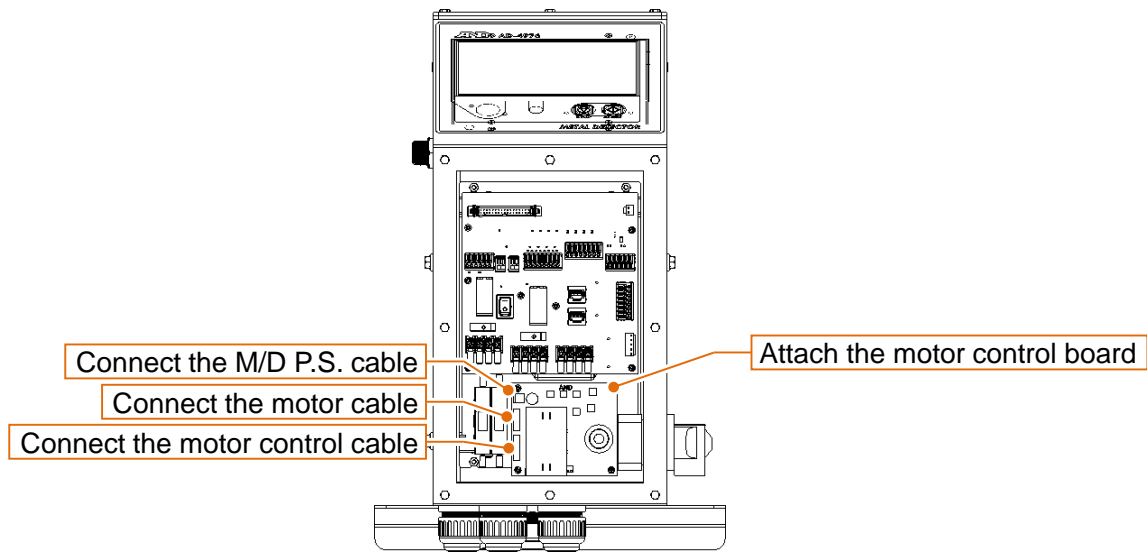

Fig. 54 Attaching the motor control board

15. Pass the screening signal cable (1KO7255A) and ground cable (1KO6966) running through the corrugated tube of the rejector to the cable gland of the AD-4976-H series. Keep the plug removed from the cable gland in a safe place.

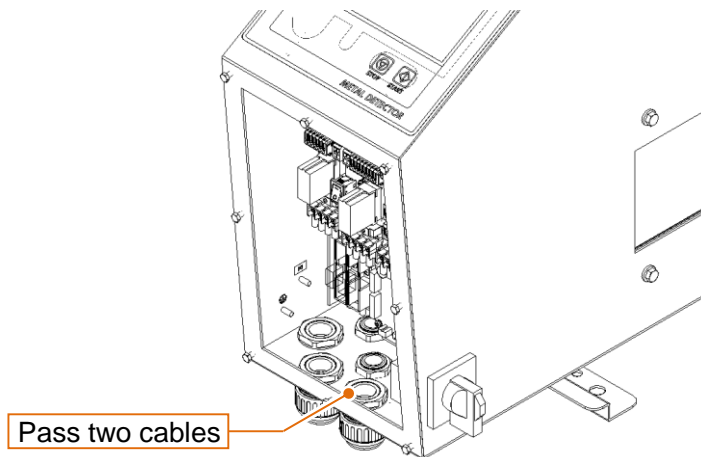

Fig. 55 Cable gland for the screening signal cable and ground cable

16. Using a 7 mm wrench, connect the ground cable (1KO6966) in **step 15** to the ground terminal on the inside wall of the AD-4976-H series.

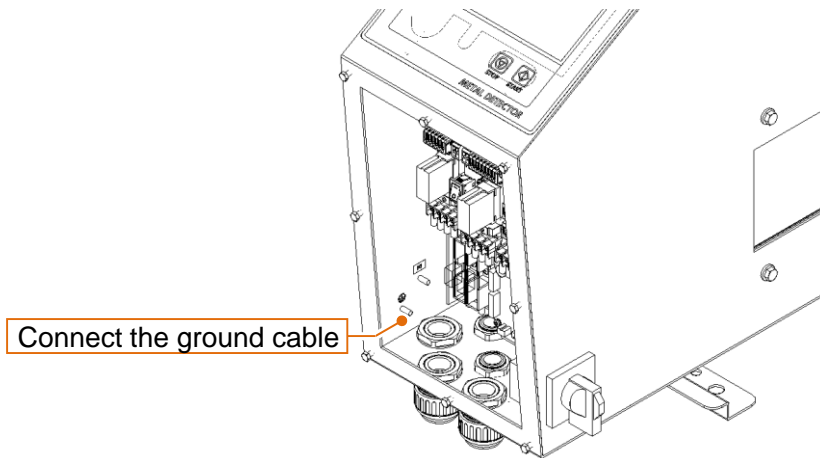

Fig. 56 Connecting the ground cable

17. Connect the screening signal cable (1KO7255A) in **step 15** to the DO3 terminal, DO4 terminal, and COM terminal on the I/O board. Then connect the 24 V crossover cable supplied with the product to the terminal of DO3 and the 24 V terminal. In the same way, connect the terminal of DO4 to the 24 V terminal.

The figure below shows an example of connection for rejection operation using DO3 and DO4 with a three-direction rejector. For a two-direction rejector, insulate unused terminals of the screening signal cable by wrapping them with tape, etc. so that the I/O board is not shorted.

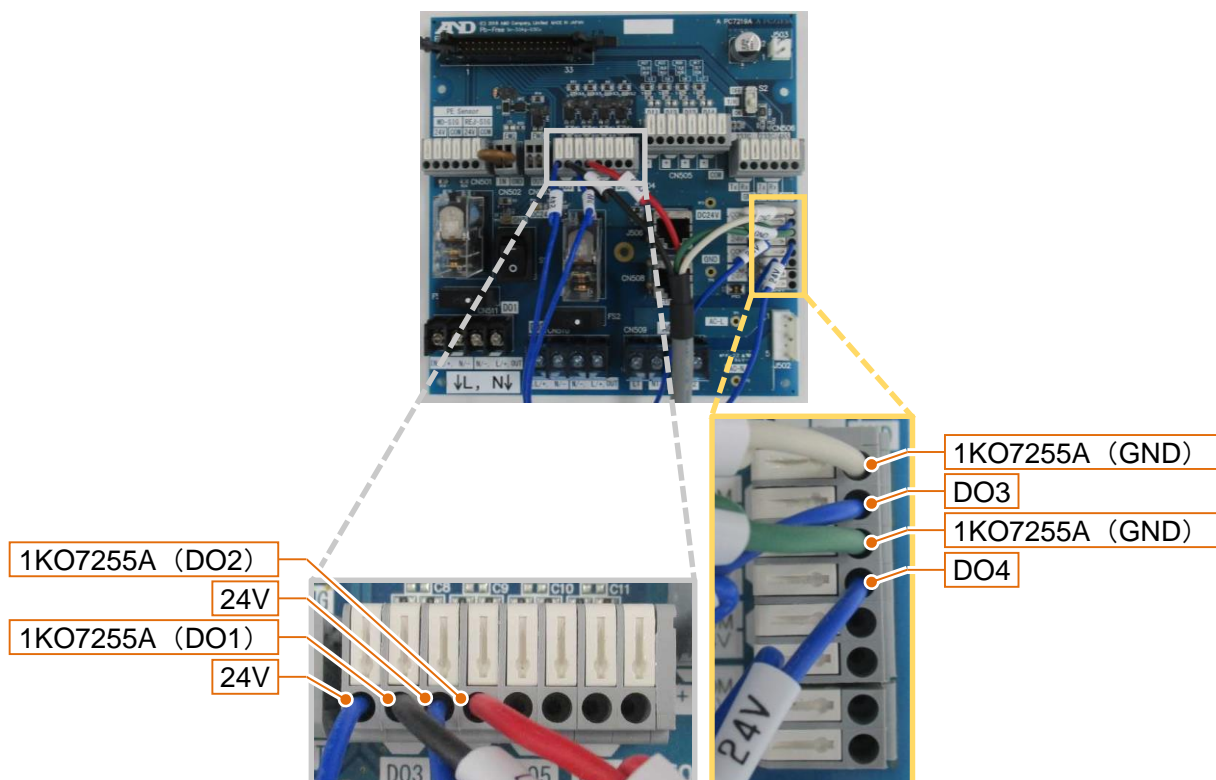

Fig. 57 Connecting the screening signal cable

18. Pass the corrugated tube through the cable gland in **step 15** and tighten the sealing nut. To maintain a waterproof and dustproof structure, insert the corrugated tube far inside.



Fig. 58 Tightening the sealing nut

19. Reattach the sensor head cover removed in **step 10**.
To maintain a waterproof and dustproof structure, tighten the hexagon head screws with a tightening torque of 1 [N·m].
20. Start supplying power to the AD-4976-H series, and set the following items as necessary.
- Belt speed adjustment
 - External device settings (rejector motor error)
 - Product settings (DO map, DO behavior)
 - DI setting
 - Reject confirmation settings (DI setting, DO map, DO behavior)

6-3 Connecting to the AD-4971 series

Caution:

To prevent injury or equipment failure during work, cut off the power supply to the AD-4971 series.

1. Change the end processing of the label L and N terminals on the AC IN cable (1KO6713 or 1KO6827) of the rejector from M3 round crimp terminals to M4 round crimp terminals (R1.25-4 or equivalent).

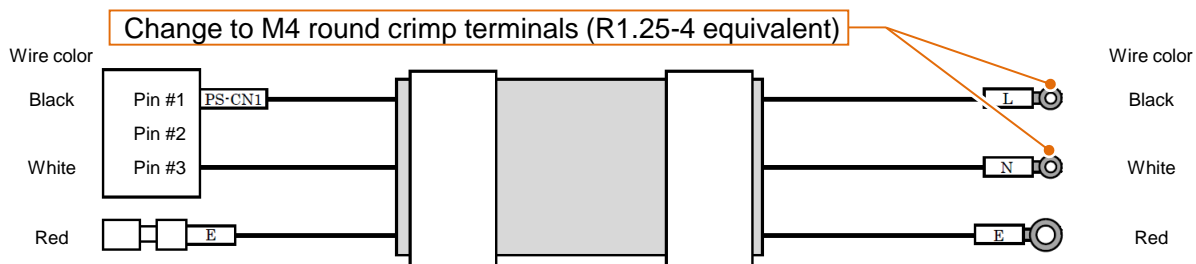

Fig. 59 Processing of the AC IN cable

2. Change the terminal processing of the screening signal cable (1KO7255A) from semi-stripped to M3 round crimp terminals (R1.25-3 or equivalent).

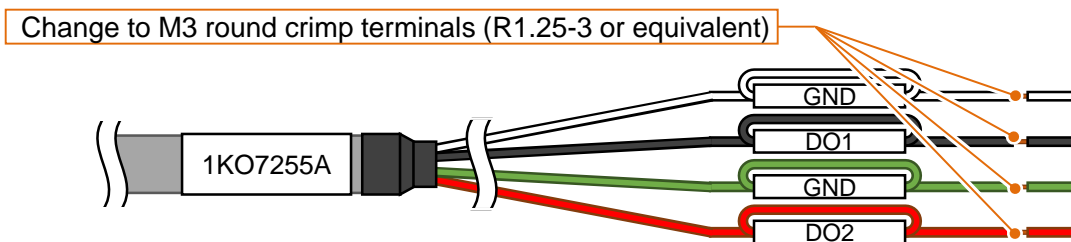

Fig. 60 Processing of the screening signal cable

3. Open the I/O box.

4. To remove the middle plate, remove the cables connected to the circuit board and terminals on the middle plate. Then, using a #2 Phillips screwdriver, remove the pan head screws to remove the middle plate.

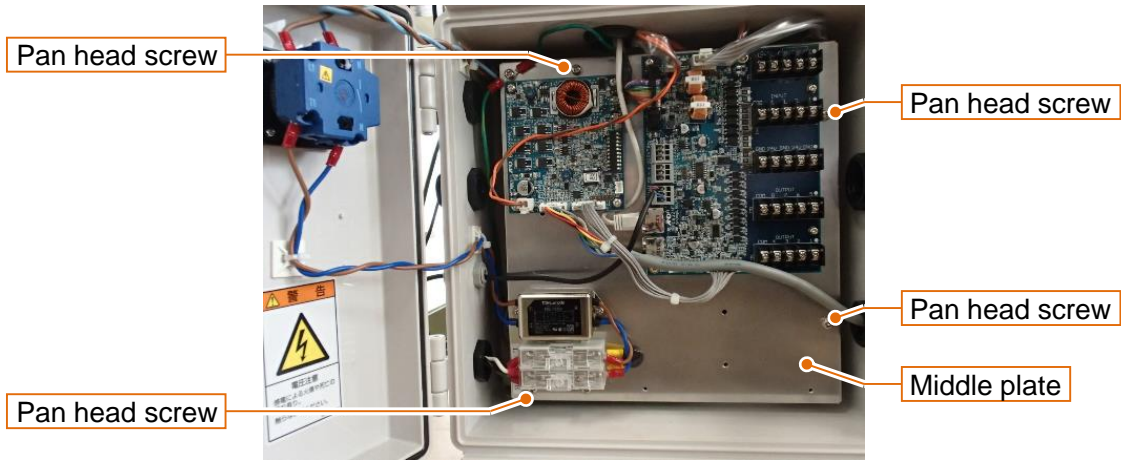

Fig. 61 Removing the middle plate of the I/O box

5. Loosen the cable gland on the left side of the I/O box and pass the AC IN cable (1KO6713 or 1KO6827) of the rejector (A). Then, using a #2 Phillips screwdriver, connect the AC IN cable to the terminal block. From the top, connect the terminals labeled E, N, and L in that order (B).

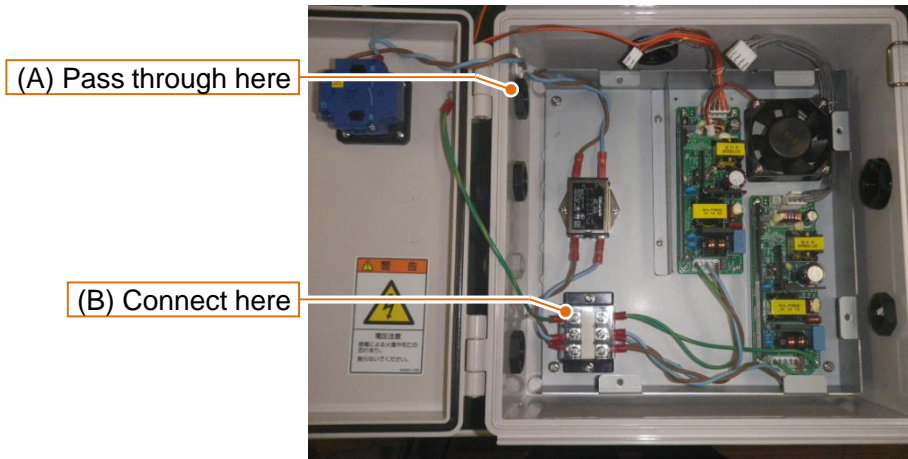

Fig. 62 Connecting the AC IN cable

6. Reattach the middle plate removed in [step 4](#).

- Loosen the cable gland on the right side of the I/O box and pass the motor control cable (1KO4338) and the screening signal cable (1KO7255A) of the rejector (A).
Then connect the motor control cable to the I/O board.

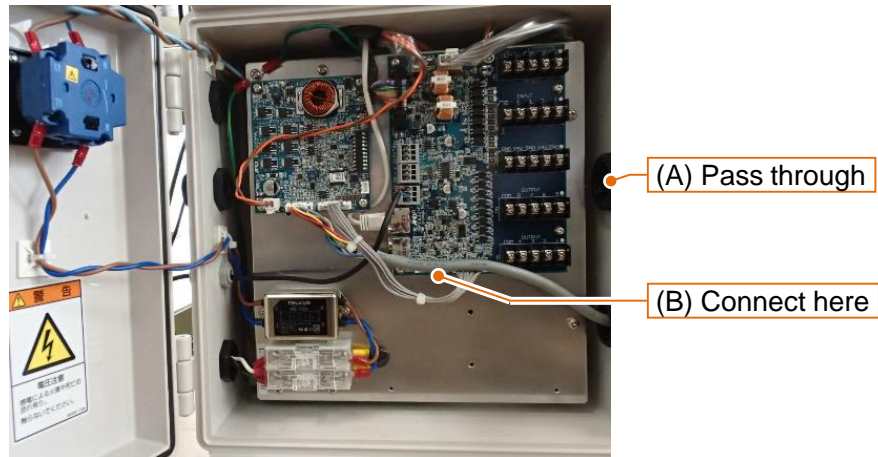

Fig. 63 Connecting the AC IN cable

- Connect the screening signal cable (1KO7255A) in [step 7](#) to the DO1 terminal, DO2 terminal, and GND terminal on the I/O board. Then, connect the supplied 24V crossover cable to the 24V terminal and the COM terminal.

The figure below shows an example of connection for rejection operation using DO1 and DO2 with a three-direction rejector.

For a two-direction rejector, insulate unused terminals of the screening signal cable by wrapping them with tape, etc. so that the I/O board is not shorted.

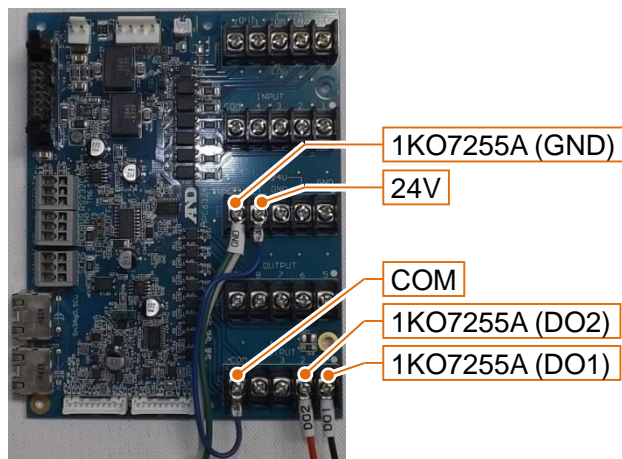

Fig. 64 Connecting the screening signal cable

9. Tighten the cable glands in **steps 5 and 7**.

Pass the corrugated tube through the cable gland that the motor control cable (1KO4338) and the screening signal cable (1KO7255A) have been passed, and then tighten the sealing nut (tightening torque 2.0 to 2.8 [N·m]).

To maintain a waterproof and dustproof structure, insert the corrugated tube far inside.



Fig. 65 Tightening the sealing nut

10. Start supplying power to the AD-4971 series, and then set the following items as necessary.

For the setting method, refer to the AD-4971 series instruction manual.

- Inspection operation setting
- DO map setting
- DO behavior setting
- Belt speed adjustment

6-4 Connecting to the AD-4961A series

Caution:

To prevent injury or equipment failure during work, cut off the power supply to the AD-4961A series.

1. Pass the motor power cable (1KO7152), motor control cable (1KO4338), screening signal cable (1KO7255A), and ground cable (1KO6966) of the AD-4981-2570 through the cable gland on the back of the AD-4961A series control box.

Keep the plug removed from the cable gland in a safe place.

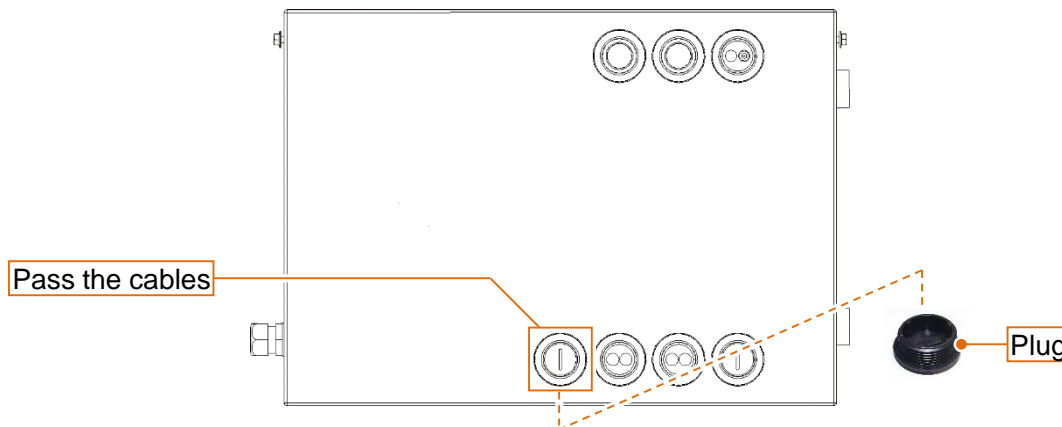

Fig. 66 Cable gland (AD-4961A series)

2. Connect the following wires to the terminal block (TB1) shown below in the control box.

- Terminal No. 12: Black wire (DO1) of the screening signal cable
- Terminal No. 11: Red wire (DO2) of the screening signal cable
- Any of terminals No. 13 to 16: The supplied 24V crossover cable

Caution: Terminals No. 13 to 16 have shorting pins connected to them and are set so that each terminal is at the same electric potential. Do not remove the short pins.

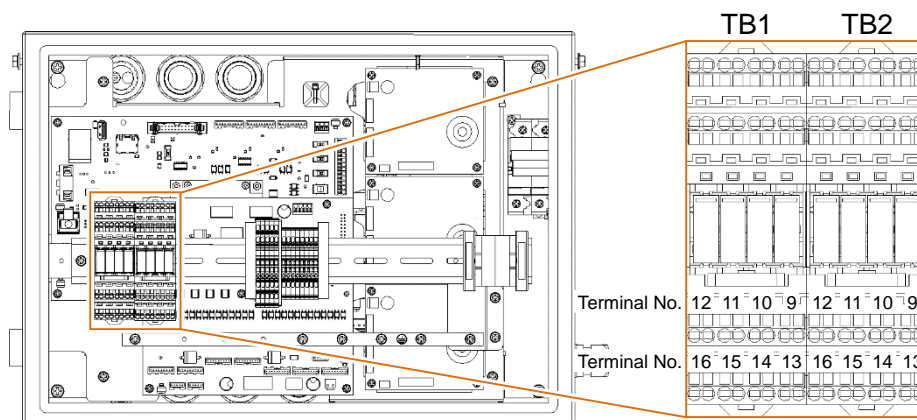

Fig. 67 Wiring to the terminal block (TB1)

3. Connect the following wires to the terminal block (TB3) shown below in the control box.
 - One of the rows of the terminal No. 1: Blue wire (24V) of the motor power cable
 - One of the rows of the terminal No. 1: The cable connected to any of the terminals No. 13 to 16 in [step 2](#)
 - One of the rows of the terminal No. 2: Blue and white wire (GND) of the motor power cable
 - One of the rows of the terminal No. 2: White wire (GND) of the screening signal cable
 - One of the rows of the terminal No. 2: Green wire (GND) of the screening signal cable

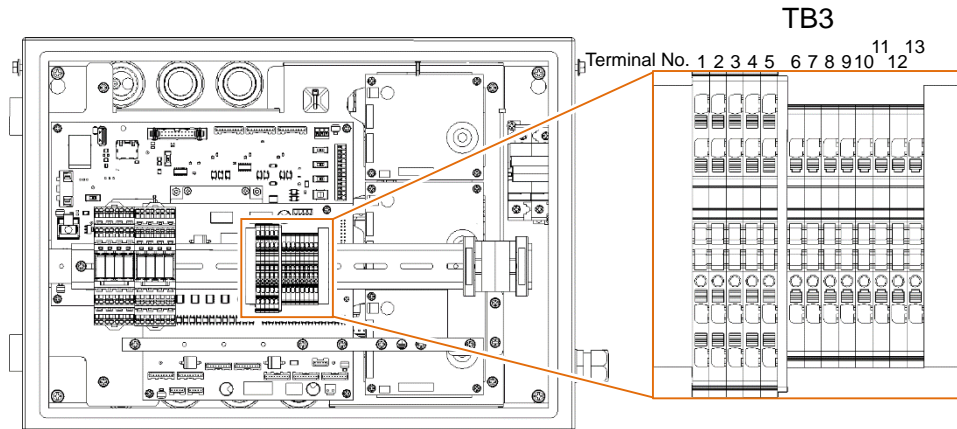

Fig. 68 Wiring to the terminal block (TB3)

Note:

[Step 2](#) and [step 3](#) show examples of connection for rejection operation using DO1 and DO2 with a three-direction rejector.

For a two-direction rejector, do not connect the red wire (DO2) and the green wire (GND) of the screening signal cable, and insulate them by wrapping them with tape or other means to prevent them from shorting other circuits.

4. Connect the motor control cable to the connector (J113) shown below in the control box.

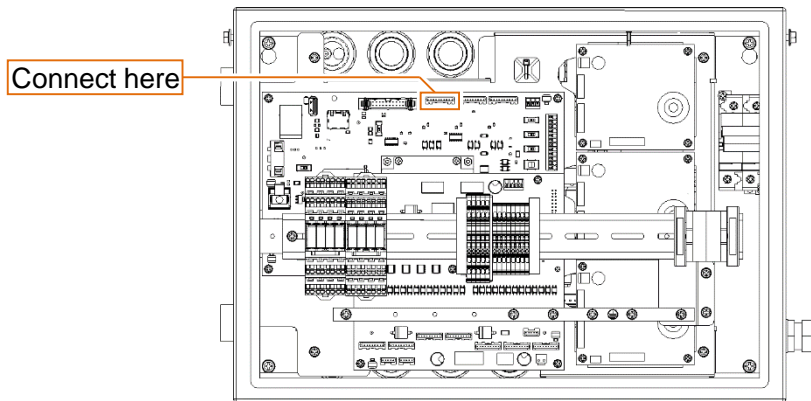

Fig. 69 Connecting the motor control cable

5. Connect the ground cable to the grounding bar shown below in the control box.

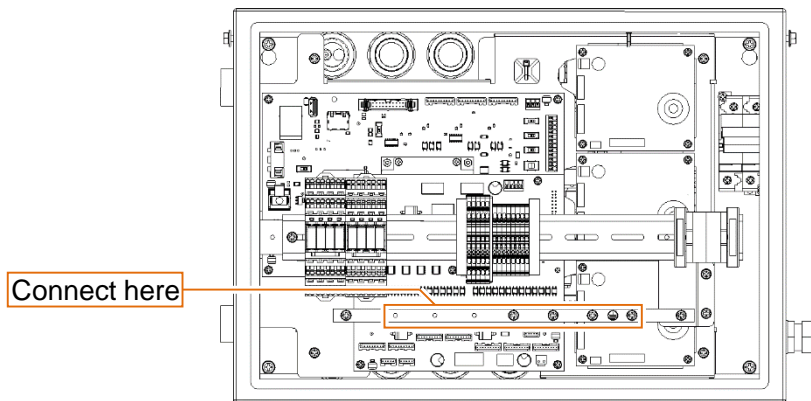

Fig. 70 Connecting the ground cable

6. Pass the corrugated tube through the cable gland, and then tighten the sealing nut loosened in [step 1](#).



Fig. 71 Tightening the sealing nut

7. Start supplying power to the AD-4961A series, and then set the following items as necessary.
 - Rejector connection settings
 - Belt settings (belt speed adjustment, error check)
 - Product settings (belt speed of rejector, DO map, DO behavior)
 - DI settings (DI setting, reject confirmation, reject timing)

7. Maintenance

7-1 Daily check

To ensure safe use, please check each part of this rejector before use.

If the status of the rejector does not match that of the check contents, please take actions as indicated.

Table 6 Daily check

No.	Check contents	Action contents
1	Make sure the installation position and height of the equipment in front of and behind the rejector allow products to be conveyed in and out.	Depending on the conditions for the floor on which the rejector is installed and the operating speed of the flipper arm, the installation position may be easily displaced by the vibration of rejection operations. If it is frequently displaced, please contact your local A&D dealer. For adjustment of the height, refer to " 5 Installation (P. 26) ."
2	Make sure the belt is not damaged, the tension of the belt is normal, and there is no meander. If conditions are not normal, the belt may be damaged.	If the belt is damaged, it needs to be replaced. Please contact your local A&D dealer. If the belt tension is abnormal or the belt is meandering, adjust the belt tension and meander (7-3 Belt meander adjustment (P. 54)).
3	Inspect products that passed and failed to check that they are screened correctly.	If products are not screened correctly, check the following. <ul style="list-style-type: none"> • The DO of the inspection machine is set • Belt speed is normal • The rejection operation can be done
4	Operate the belt and check that there is no abnormal noise or other abnormality in the motor or gear.	If there is abnormal noise or other abnormality, the motor or gear needs to be replaced. Please contact your local A&D dealer.

7-2 Belt installation/removal

7-2-1 Removing the belt

Caution:

To prevent injury or equipment failure during work, cut off the power supply to the inspection system (X-ray inspection system, checkweigher, or metal detector) connected to the rejector.

1. Turn the belt tension adjusting screws inward to loosen the belt tension.

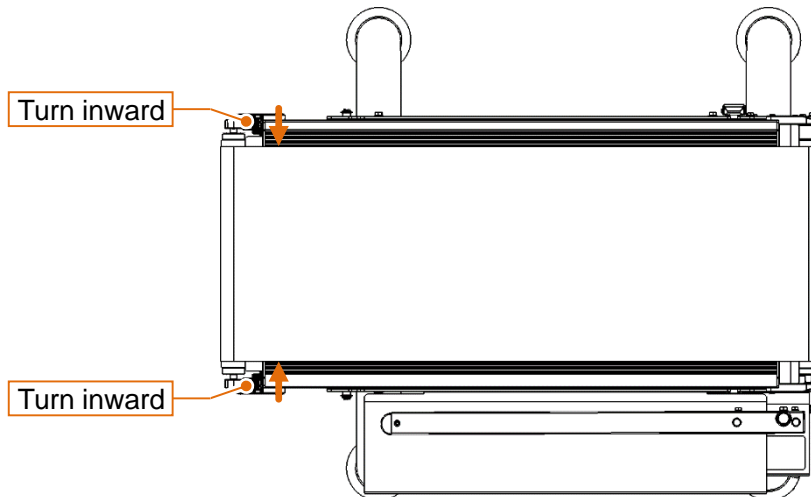

Fig. 72 Adjusting (loosening) the belt tension

2. Lift the chute plate from the plate holders (A).
Then remove the chute plate from the chute plate retainers (B).

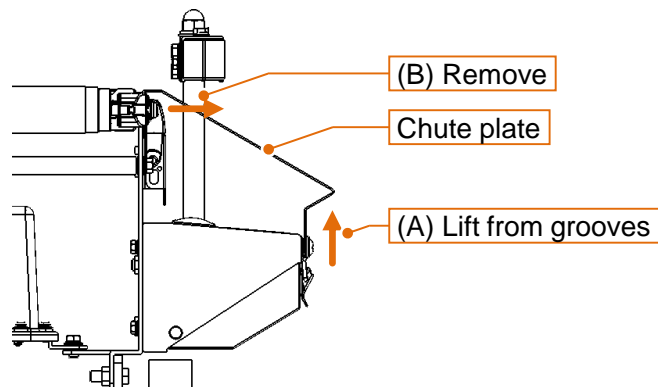

Fig. 73 Removing the chute plate

3. Release the draw latches of the conveyor.

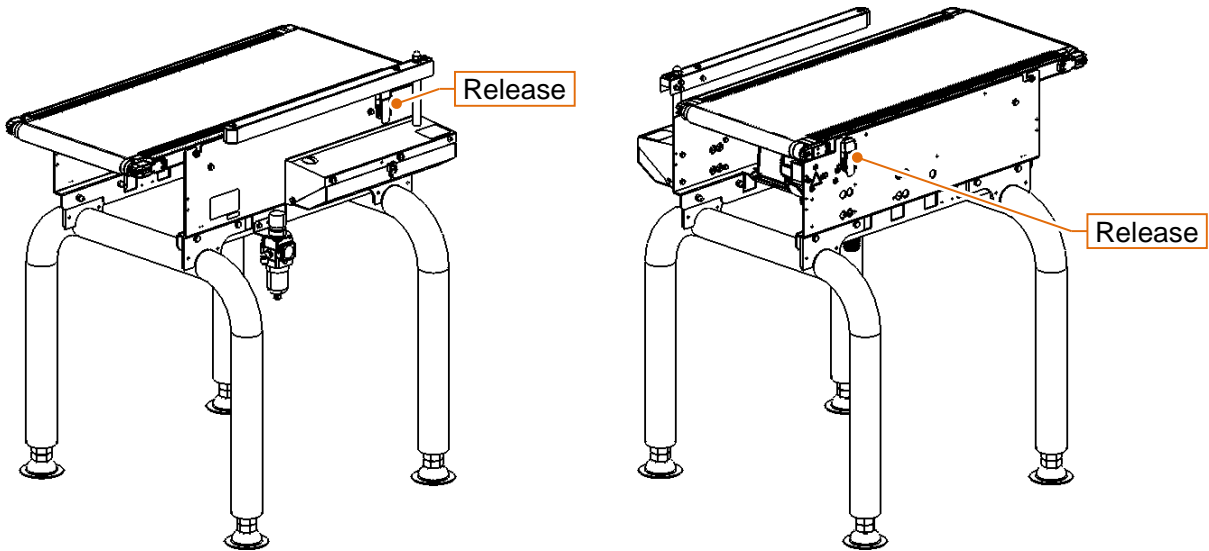

Fig. 74 Releasing the draw latches of the conveyor

4. Lift the conveyor draw latch side of the conveyor base (A).
Next, slide the conveyor base towards the side of the conveyor draw latches (B).
Then lift the conveyor base and remove it from the rejector main unit (C).

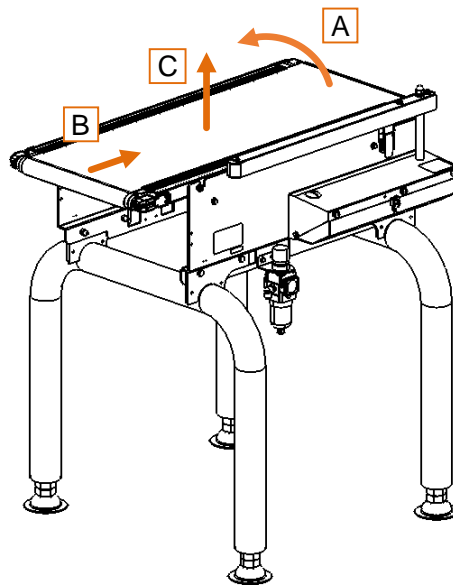

Fig. 75 Removing the conveyor base

5. Remove the belt from the removed conveyor base.

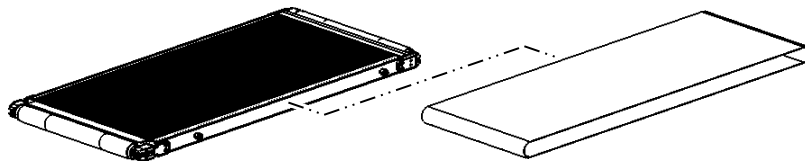

Fig. 76 Removing the belt

7-2-2 Attaching the belt

Caution:

To prevent injury or equipment failure during work, cut off the power supply to the inspection system (X-ray inspection system, checkweigher, or metal detector) connected to the rejector.

1. If the conveyor base is not removed from the rejector, refer to "[7-2-1 Removing the belt \(P. 49\)](#)" and remove the conveyor base from the rejector.
2. Attach the belt to the conveyor base.
If it is difficult to attach the belt, turn the belt tension adjusting screws inward.

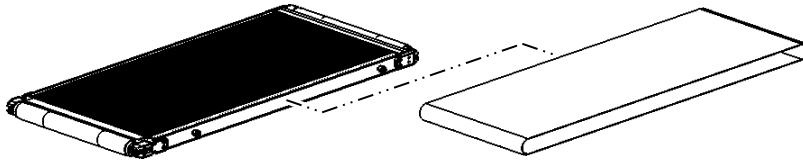

Fig. 77 Attaching the belt

3. Place the conveyor base (the side opposite the draw latches of the conveyor) on the rejector main unit (A).
Next, slide the conveyor base to the side opposite the draw latches of the conveyor (B).
Then place the conveyor base (the side of the draw latches of the conveyor) on the rejector main unit (C).

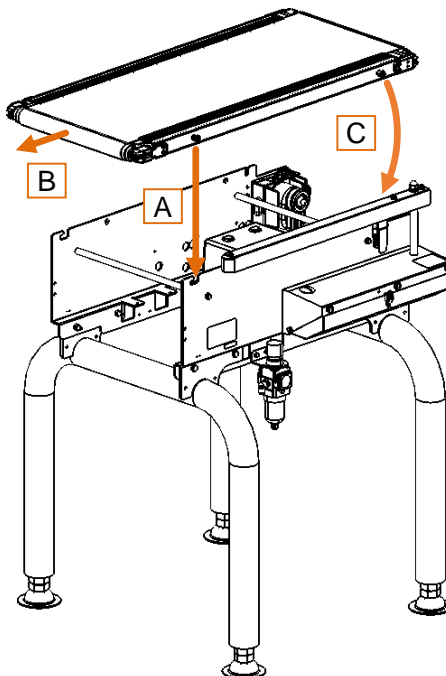

Fig. 78 Attaching the conveyor base

4. Close the draw latches of the conveyor to secure the conveyor base to the rejector main unit.

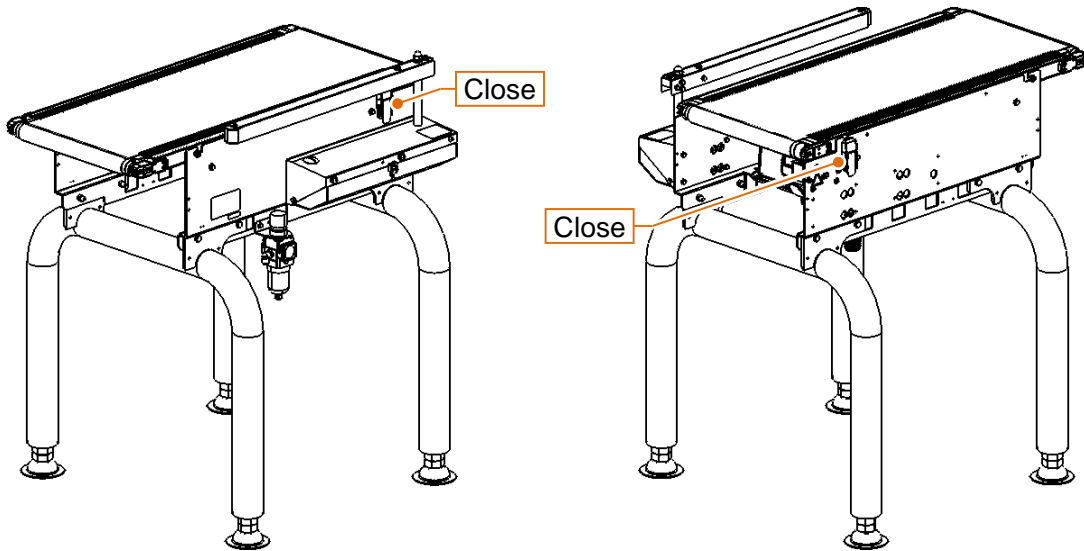

Fig. 79 Closing the draw latches of the conveyor

5. Insert the chute plate into the chute plate retainers (A).
Next, place the chute plate into the grooves of the plate holders (B).

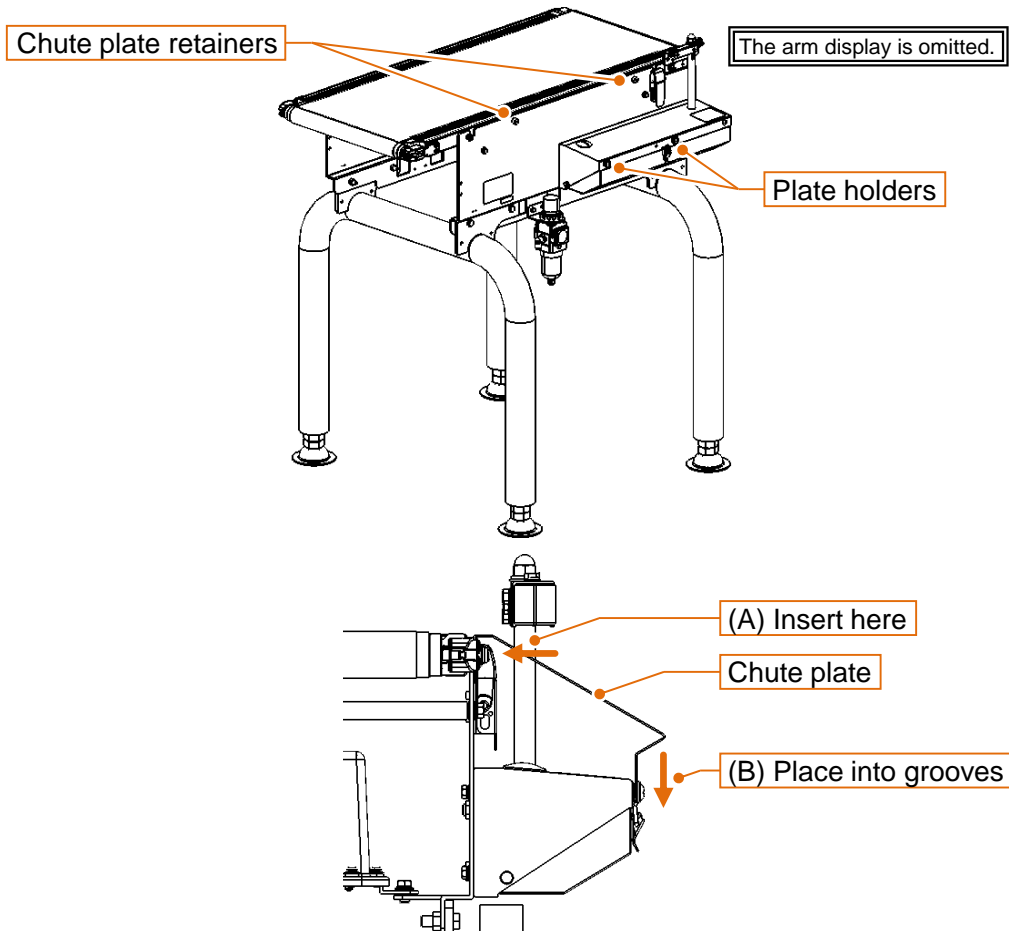

Fig. 80 Attaching the chute plate

- Turn the belt tension adjusting screws outward to increase the belt tension.
Adjust the belt meander as necessary ([7-3 Belt meander adjustment \(P. 54\)](#)).

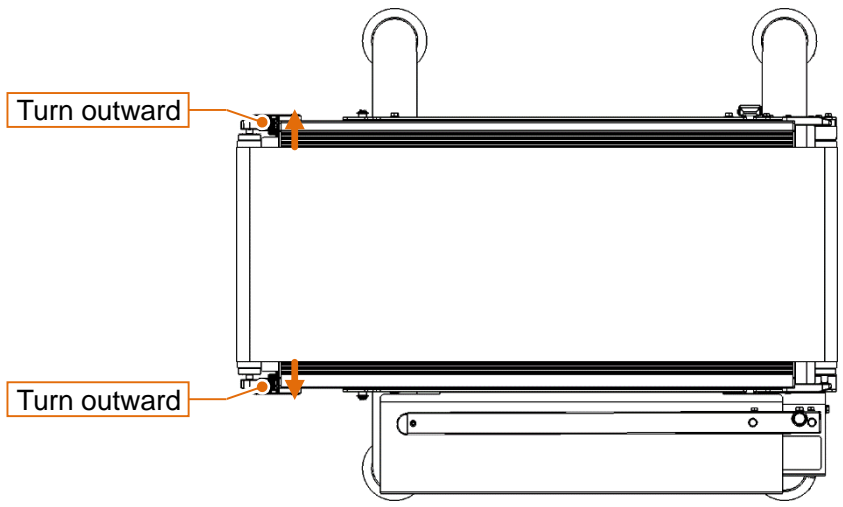

Fig. 81 Adjusting the belt tension (to stretch)

7-3 Belt meander adjustment

Caution:

The belt is running during belt meander adjustment work. Be careful not to let your fingers or clothes get caught in the running belt.

1. Operate the inspection system to operate the belt of the rejector.
2. Check if the belt meanders.
3. The belt meanders in the loosened direction.

The belt also meanders in the opposite direction of the tensioned direction.

Tension the belt in the direction of meandering (by turning the belt tension adjustment screw outward) or loosen the belt tension in the opposite direction (by turning the belt tension adjustment screw inward).

Be careful not to over-tension or over-loosen the belt.

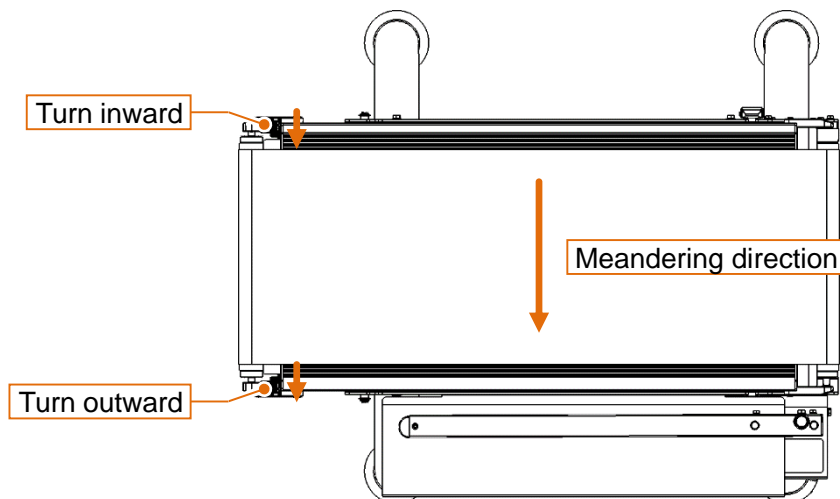

Fig. 82 Example of meandering adjustment (meandering to front side of the rejector)

4. Repeat **steps 2 and 3** until the belt no longer meanders.
5. Operate the inspection system to stop the belt of the rejector.

7-4 Belt cleaning

In order to maintain a hygienic environment, please clean the rejector if it becomes noticeably dirty. If it becomes very dirty, the performance of the rejector may deteriorate.

Caution:

- To prevent injury or equipment failure during work, cut off the power supply to the inspection system (X-ray inspection system, checkweigher, or metal detector) connected to the rejector.
 - Clean the inside of the belt as any dirt may cause performance degradation.
1. Remove the belt ([7-2-1 Removing the belt \(P. 49\)](#)).
 2. Wipe off any dirt from the belt with a soft cloth. If it is very dirty, wipe off with lukewarm water at 60 °C or below, or a neutral detergent.
 3. When the dirt is removed, wipe off the remaining water drops with a soft cloth.
 4. Attach the belt ([7-2-2 Attaching the belt \(P. 51\)](#)).

7-5 Flipper arm operating speed adjustment

Adjust the speed controller inside the cylinder case to adjust the operating speed of the flipper arm.

- A) Adjust the amount of air supplied when extending the air cylinder and the amount of air discharged when retracting.
- B) Adjust the amount of air discharged when extending the air cylinder and the amount of air supplied when retracting.

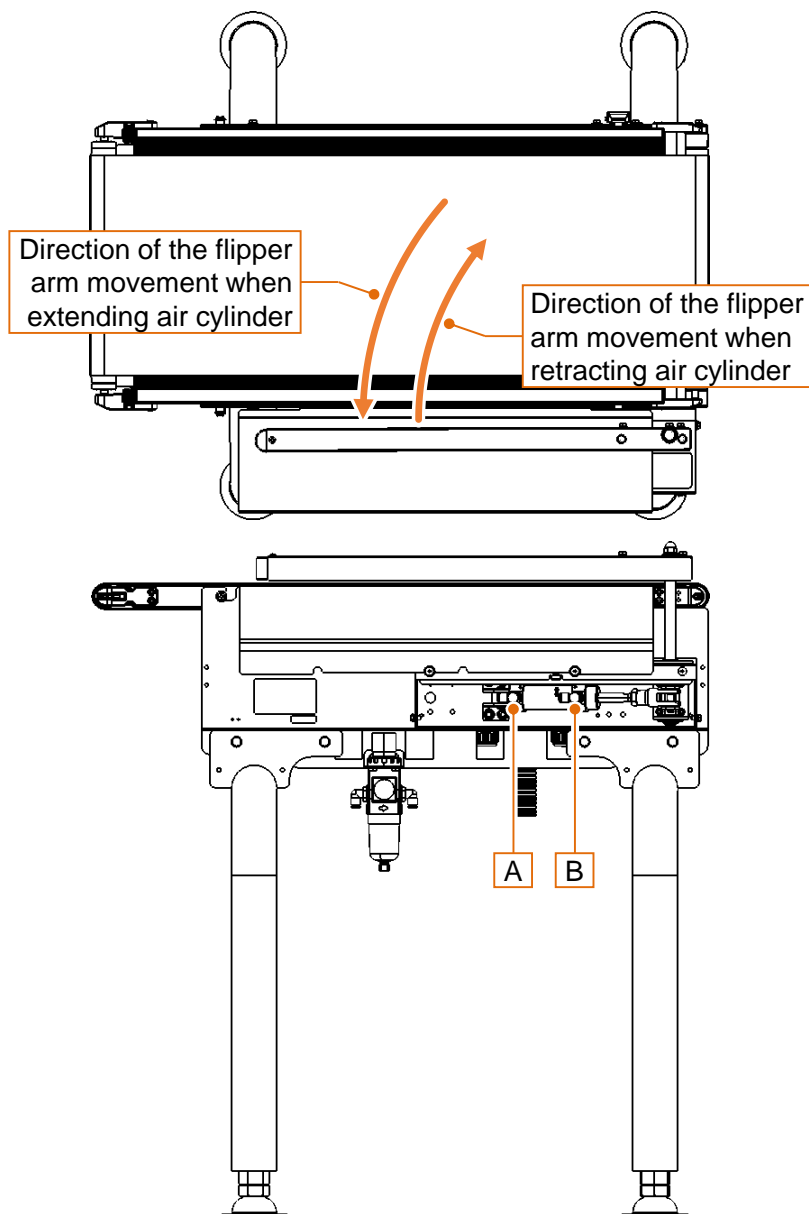

Fig. 83 Adjusting the flipper arm operating speed

8. Specifications

Table 7 Specifications

Specifications	AD-4981-2570
Conveyor width	250 mm
Rejector length	700 mm
Conveyor height *1	720 to 860 mm
Conveyor speed *2	10 to 80 m/min
Screening capacity *3	100 pcs/min
Air source	0.5 MPa, 0.2 NL/time φ 6 mm urethane air tube quick joint type
Conveyor load capacity	Up to 3 kg
Operating temperature/humidity	0 to 40 °C / below 85%RH, with no condensation
Dust-/water-proof protection rating	IP65
Maximum power consumption	Approx. 60 W
Weight	Main unit: 13.6 kg Arm unit: 3.3 kg Base unit: 8.2 kg
Belt material	Polyurethane

*1: Value when AD-4981-C2570 and AD-4981-B2570 are combined.

*2: This is the specification of the rejector. Depending on the model connected, it may not be usable in the high-speed range.

*3: Varies depending on the shape and condition of the product and the installation environment.

9. External dimensions

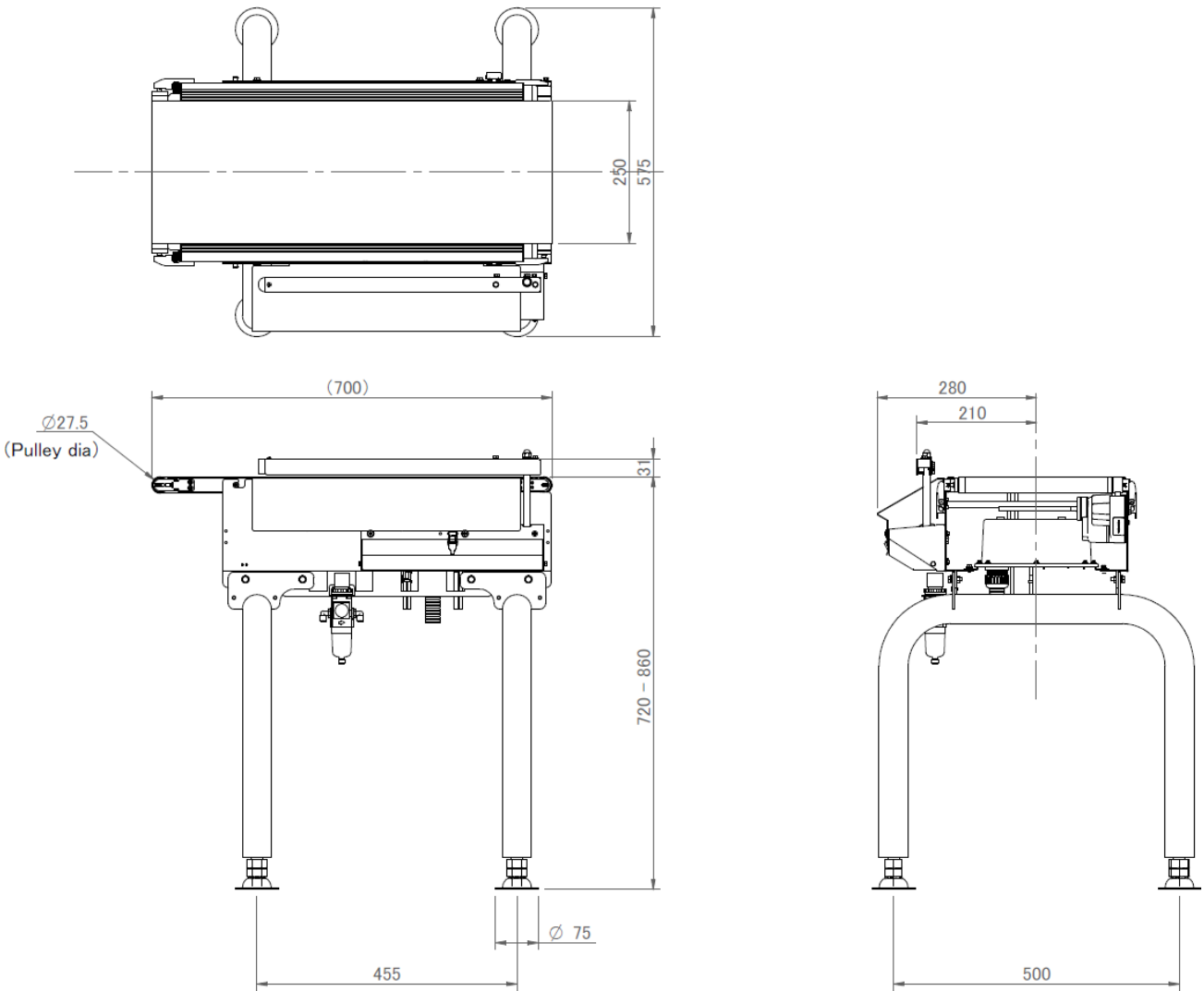

Fig. 84 External dimensions (standard)

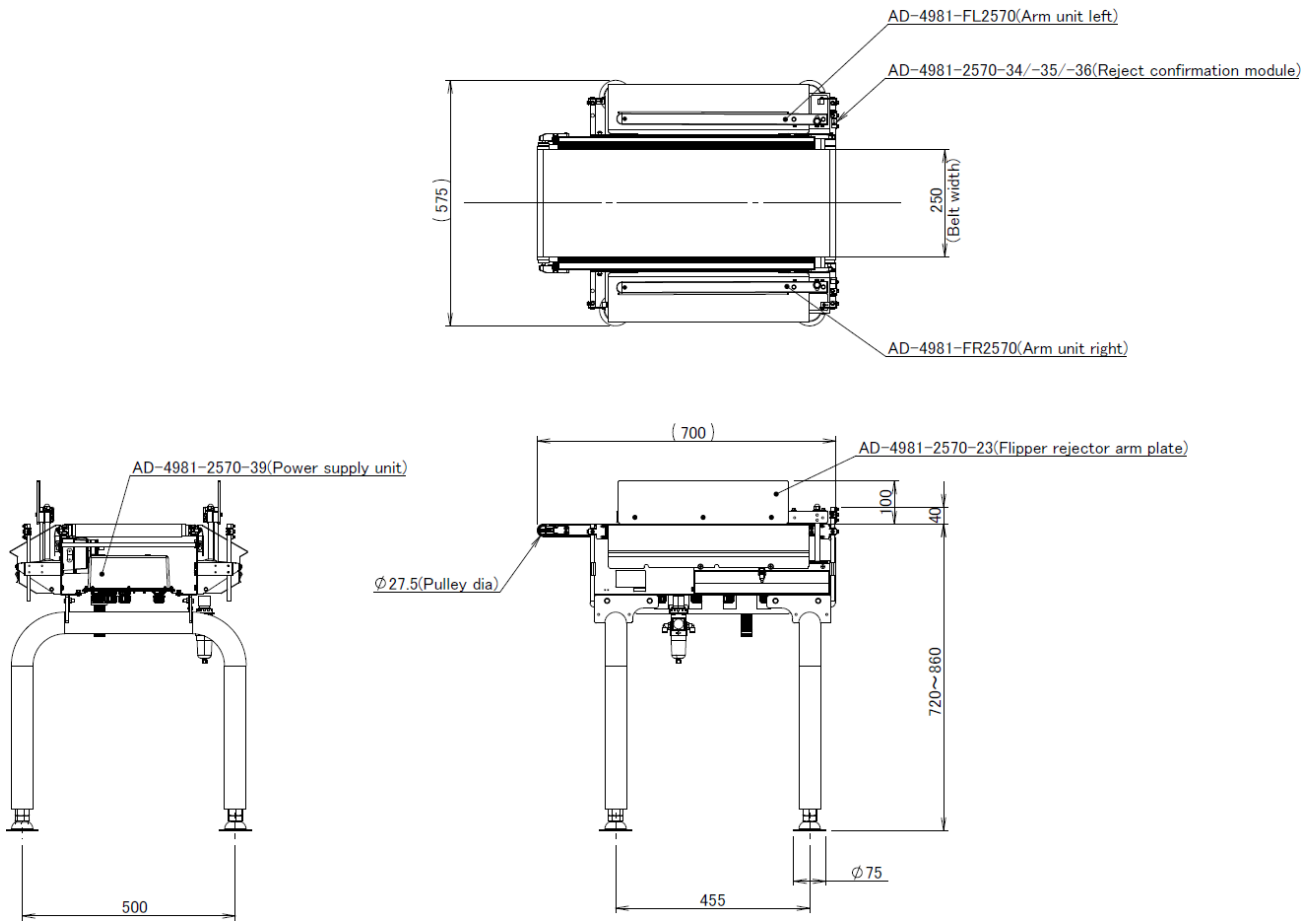

Fig. 85 External dimensions (when products sold separately are installed)

10. List of consumables

Major consumables are listed below.

The models listed are subject to change without notice. Please contact your A&D dealer for details.

Table 8 List of consumables (AD-4981-2570 series)

No.	Name	Model	Qty. of use
1	Conveyor belt	110NP4427-05	1
2	Resin gear pack (set of numbers 3 and 4)	AX-GP4991-2515	1
3	Resin gear (pulley side)	7PA-49XX-GEAR02	1
4	Resin gear (motor side)	7PA-49XX-GEAR06	1
5	Motor unit (includes numbers 3 and 4)	1PA4981-4-2570	1
6	Driving pulley	7PA4961-25K	1
7	Driven pulley	7PA4961-250	1

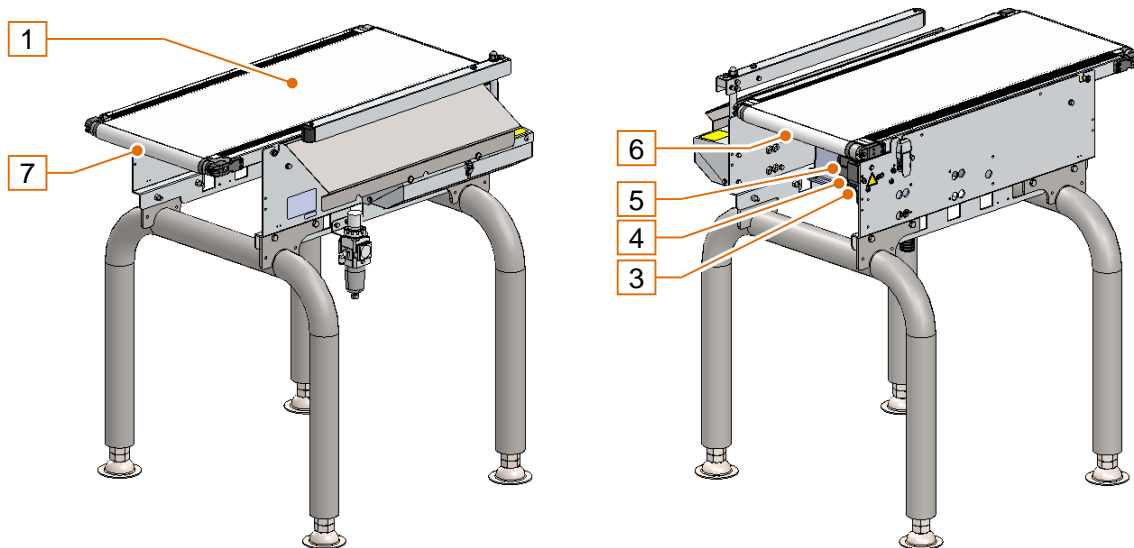

Fig. 86 Consumables arrangement diagram (AD-4981-2570 series)

11. Required tools

Table 9 Required tools

Name	Specification	Application
Phillips screwdriver	#0	<ul style="list-style-type: none"> • Assembly of flipper arm (sold separately)
Phillips screwdriver	#2	<ul style="list-style-type: none"> • Assembly of flipper arm (sold separately) • Assembly of power supply unit (sold separately) • Assembly of flipper rejector arm plate (sold separately) • Connection with AD-4976-H series • Connection with AD-4971 series • Connection with AD-4961A series
Flat-head screwdriver	Blade width 2.5 mm	<ul style="list-style-type: none"> • Connection with AD-4991 series • Connection with AD-4961A series
Wrench	Width across flats 7 mm	<ul style="list-style-type: none"> • Assembly of main unit • Assembly of flipper arm (sold separately) • Assembly of reject confirmation unit (sold separately) • Assembly of flipper rejector arm plate (sold separately) • Connection with AD-4991 series • Connection with AD-4976-H series
Wrench	Width across flats 8 mm	<ul style="list-style-type: none"> • Assembly of flipper arm (sold separately) • Assembly of power supply unit (sold separately) • Assembly of flipper rejector arm plate (sold separately)
Wrench	Width across flats 10 mm	<ul style="list-style-type: none"> • Assembly of main unit
Wrench	Width across flats 13 mm	<ul style="list-style-type: none"> • Assembly of flipper arm (sold separately) • Assembly of flipper rejector arm plate (sold separately)
Wrench	Two pcs., width across flats 30 mm	<ul style="list-style-type: none"> • Installation (adjusting the height)
Adjustable wrench		<ul style="list-style-type: none"> • Assembly of flipper arm (sold separately)
Long-nose pliers	Approx. 150 to 160 mm in total length	<ul style="list-style-type: none"> • Connection with AD-4976-H series
Hexagon pin wrench	Width across flats 2 mm	<ul style="list-style-type: none"> • Assembly of reject confirmation unit (sold separately)
Crimping tool	Crimpable to R1.25-3 and R1.25-4 equivalent	<ul style="list-style-type: none"> • Connection with AD-4971 series

12. Revision History

Table 10 Revision history

Date	Part number	Description of issue
2020-10-06	1WMPD4004180	First edition
2024-06-01	1WMPD4004180A	<ul style="list-style-type: none">• Changed the shape of the chute plate and the installation procedure.• Added a section on assembly procedures for the optional product AD-4981-23.• Changed the connection procedure with AD-4991 series to correspond to the new main board.• Added a section on connection procedures for AD-4961A series.• Added a chapter on the list of consumables.• Added a chapter on the required tools.

THIS PAGE INTENTIONALLY LEFT BLANK.



A&D Company, Limited

3-23-14 Higashi-Ikebukuro, Toshima-ku, Tokyo 170-0013, JAPAN
Telephone: [81] (3) 5391-6132 Fax: [81] (3) 5391-1566

A&D ENGINEERING, INC.

47747 Warm Springs Blvd, Fremont, California 94539, U.S.A.
Tel: [1] (800) 726-3364 Weighing Support:[1] (888) 726-5931 Inspection Support:[1] (855) 332-8815

A&D INSTRUMENTS LIMITED

Unit 24/26 Blacklands Way, Abingdon Business Park, Abingdon, Oxfordshire OX14 1DY United Kingdom
Telephone: [44] (1235) 550420 Fax: [44] (1235) 550485

A&D AUSTRALASIA PTY LTD

32 Dew Street, Thebarton, South Australia 5031, AUSTRALIA
Telephone: [61] (8) 8301-8100 Fax: [61] (8) 8352-7409

A&D KOREA Limited

한국에이.엔.디(주)
서울특별시 영등포구 국제금융로6길33 (여의도동) 맨하탄빌딩 817 우편 번호 07331
(817, Manhattan Bldg., 33. Gukjegeumyung-ro 6-gil, Yeongdeungpo-gu, Seoul, 07331 Korea)
전화: [82] (2) 780-4101 팩스: [82] (2) 782-4264

OOO A&D RUS

ООО "ЭЙ энд ДИ РУС"

Почтовый адрес:121357, Российская Федерация, г.Москва, ул. Вереysкая, дом 17
Юридический адрес: 117545, Российская Федерация, г. Москва, ул. Дорожная, д.3, корп.6, комн. 86
(121357, Russian Federation, Moscow, Vereyskaya Street 17)
тел.: [7] (495) 937-33-44 факс: [7] (495) 937-55-66

A&D Instruments India Private Limited

ऐ&डी इन्स्ट्रुमेंट्स इण्डिया प्रा० लिमिटेड

D-48, उद्योग विहार , फेस -5, गुडगांव - 122016, हरियाणा , भारत
(D-48, Udyog Vihar, Phase-V, Gurgaon - 122016, Haryana, India)
फोन : [91] (124) 4715555 फैक्स : [91] (124) 4715599

A&D SCIENTECH TAIWAN LIMITED. A&D台灣分公司 艾安得股份有限公司

台湾台北市中山區南京東路2段206號11樓之2
(11F-2, No.206, Sec.2, Nanjing E.Rd., Zhongshan Dist., Taipei City 10489, Taiwan, R.O.C.)
Tel : [886](02) 2322-4722 Fax : [886](02) 2392-1794

A&D INSTRUMENTS (THAILAND) LIMITED

บริษัท เอ แอนด์ ดี อินสตรูमेंท์ (ไทยแลนด์) จำกัด

168/16 หมู่ที่ 1 ตำบลรังสิต อำเภอธัญบุรี จังหวัดปทุมธานี 12110 ประเทศไทย
(168/16 Moo 1, Rangsit, Thanyaburi, Pathumthani 12110 Thailand)
Tel : [66] 20038911