

AD-4961A

CHECKWEIGHER



Discover Precision

Checkweigher with best-in-class 0.01g resolution and high level 0.08 g (3σ) accuracy



AD-4961A-2KD2035
 +
 Stainless Steel Cover
 (option)
 +
 Display Stand (option)



Accuracy in high speed range is improved by max. 80%.* Contributes to increased productivity

The design has evolved to be less susceptible to wind and vibration than previous models, and environmental resistance has been greatly improved.

AD-4961A series is equipped with a new CPU which has increased processing power, and the newly implemented vibration elimination filter HPDF (High Performance Digital Filter) has been optimized to increase accuracy by up to 80% at high speeds. *

Checkweighing process can be performed better at high speed range than conventional models, contributing to improved production capacity and efficiency.

* When compared to data from A&D's conventional models



Better accuracy in high speed range improved by increased environmental resistance and newly equipped HPDF (High Performance Digital Filter)

A&D's Checkweighers are used by customers in a variety of industries around the world, especially in the food industry. As a weighing product manufacturer that is well received by a wide range of customers, we have developed a Checkweigher that has evolved to enable faster processing. It is equipped with a load cell developed specifically for Checkweighers and a new CPU, as well as being waterproof (IP65 grade) as standard while being priced reasonably.

High accuracy (3σ): 0.08 g

A&D has achieved high accuracy (0.08 g, 3σ) by installation of a newly designed digital load cell unit and a CPU which enables high speed processing.



High repeatability checkweighing by optimizing checkweighing settings

The optimum checkweighing settings are automatically set when the weight and length of weighed products, and throughput or conveyor belt speed are input. Setting for vibration elimination filter (HPDF) is also automatically selected. So, checkweighing can be performed easily regardless of the operator. Also, dynamic compensation can also be set easily by passing products through repeatedly.

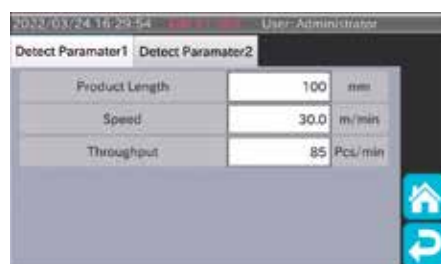

Assures consistent quality by way of the Operation History function and restricting operation according to user level

Each user is registered and user level function allows you to restrict operations for each registered user. The Operation History, which records users and operation details, as well as Weighing History can be saved onto a USB flash drive. Weighing History can be summed up as a record for HACCP management by receiving signals of inspection results from an X-ray inspection system or a metal detector.



Touchscreen has evolved to be even easier to read and use, making it easy to set up even for first-time users.

Waterproof structure: IP65

Stainless steel cover for display unit is available as an option.

Equipped with a 7-inch color touchscreen and a new CPU, operability has been improved and AD-4961A series is easier to use.

AD-4961A series have high visibility and operability, and even first-time users can easily set up the system. By registering and displaying a photo of the weighed product, a user can immediately check what product is being produced. The standard display unit is made of a reasonably priced, waterproof resin. If preferred, a stainless steel cover is also available as an option.



USB interface as standard specification



A wide variety of external interfaces for various types of communication.

The provided contact points can be used to connect the outputs of Rejector and/or alarm, and also for the inputs from a metal detector or an X-ray inspection system, etc.

RS-232C or RS-485 (selectable) interface (for connecting to Modbus RTU, barcode reader, PC, PLC, etc.), wireless LAN functionality (for remote monitoring), wired LAN interface (for remote operation, Modbus TCP/IP, etc.), and USB interface are provided as standard features. These various connection interfaces enable a Checkweigher to be connected to an X-ray inspection system and/or metal detector.

Furthermore, data can be saved to a USB flash drive and output to a printer.

In addition, the communication function enables interlocking and linking to other devices in the production line.

* Modbus is a communication protocol developed by Modicon, Inc.

Automatic switching of product settings by reading barcode.

By reading the barcode on a product, the product settings on the Checkweigher are automatically switched to those of the scanned product.

*Barcode reader shall be prepared by the customer.

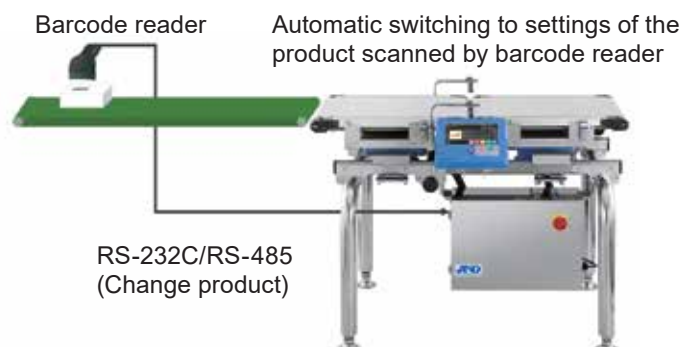

Waterproof (IP65) as standard.
 Easy to install Checkweigher that can easily be integrated with other equipment.

PDF output function reduces report creation time.
 Screenshots can also be saved.

Summary results, control charts, and histograms can be displayed. After checkweighing is complete, press the "PDF output" or "CSV output" key on the Summary screen of the data you want to save, and each file will be output to a USB flash drive. A screenshot of the touchscreen can easily be saved to a USB flash drive by pressing the camera icon in the upper right corner. You can use this function to create work instructions, manuals, and various reports.

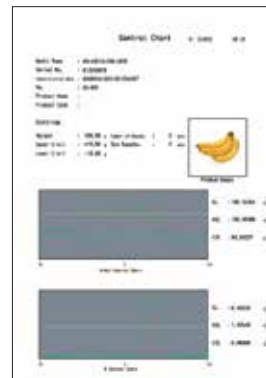

Wireless LAN as standard feature enables remote monitoring.
 Also, remote maintenance is available.

Wireless LAN function is equipped as a standard feature. *1 *2 Various data such as Summary Data can be monitored on tablets, etc., in another room, even during weighing. Also, you can operate a Checkweigher from a PC by connecting it to a PC. In addition, the AD-4961A can be used for offsite maintenance by "remotely operating *3" a PC connected to the AD-4961A via LAN from another PC in a remote location via an Internet connection.

*1 The standard wireless LAN is for monitoring only and cannot be used for remote operation.

*2 Wireless LAN can be used depending on the regulations in your region.

*3 In addition to the AD-4961A, other necessary equipment such as a PC and an Internet connection must be provided by the customer.



Settings can be changed from a PC in a remote place.

Product line-up

Compact, high-speed model AD-4961A-6001224



0.01 g resolution, best-in-class for load cell type.
Best model for checkweighing with high accuracy at high speed.

- Capacity: 600 g
- Resolution: 0.01 g
- Accuracy (3 σ): 0.08 g
- IP Rating: IP65
- Conveyor belt width: 120 mm
- Max. throughput: 400 pcs/min

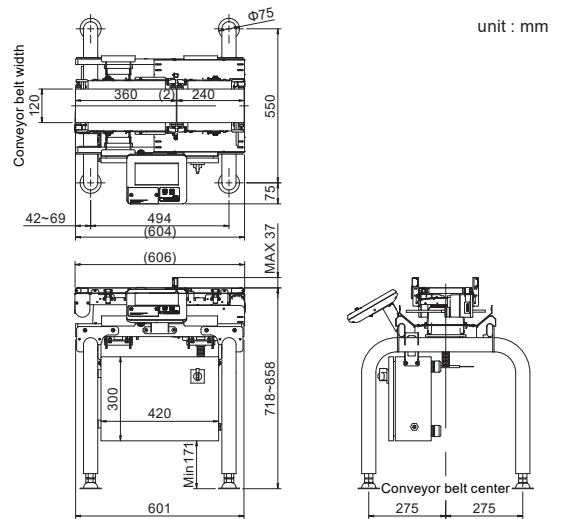

Compact dual range model AD-4961A-2KD2035



Bestselling model in the series with dual range capability that combines versatility and high precision.

- Capacity (Dual range): 500 g / 2,000 g
- Resolution: 0.01 g / 0.1 g
- Accuracy (3 σ): 0.08 g / 0.18 g
- IP Rating: IP65
- Conveyor belt width: 200 mm
- Max. throughput: 320 pcs/min

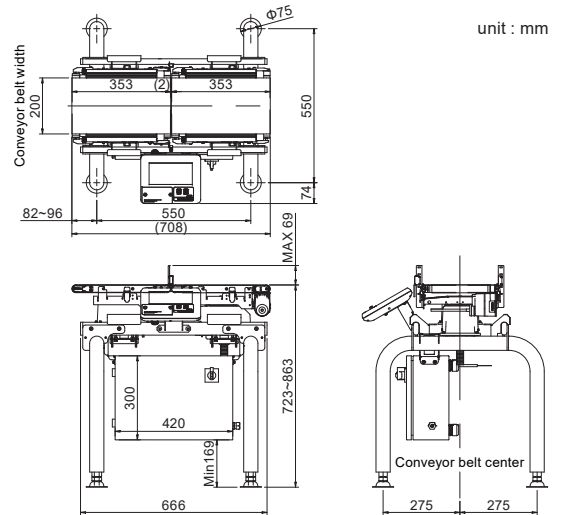

Mid-size model AD-4961A-6K3050



0.1 g resolution with 1 g accuracy for 6,000 g capacity model.
Best model for good accuracy even on a mid-sized model.

- Capacity: 6,000 g
- Resolution: 0.1 g
- Accuracy (3 σ): 1 g
- IP Rating: IP65
- Conveyor belt width: 300 mm
- Max. throughput: 145 pcs/min

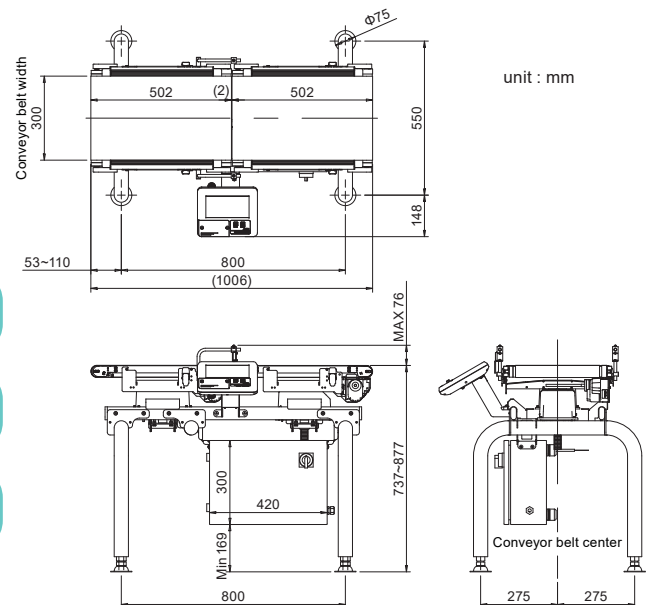



Specification

Model	AD-4961A-6001224	AD-4961A-2KD2035	AD-4961A-6K3050
Capacity	600 g	500 g / 2,000 g	6,000 g
Resolution	0.01 g	0.01 g / 0.1 g	0.1 g
Accuracy (3 σ)*1	0.08 g	0.08 g / 0.18 g	1.0 g
Max. throughput	400 pcs/min	320 pcs/min	145 pcs/min
Conveyor belt width	120 mm	200 mm	300 mm
Conveyor length	Weighing: 240 mm, Infeed: 360 mm	350 mm	500 mm
Transport medium	Urethane belt		
Conveyor belt speed	15 to 120 m/min		10 to 80 m/min
Product length	22 to 200 mm	30 to 300 mm	80 to 450 mm
Max. product width	120 mm	200 mm	300 mm
Weighing sensor	Strain gauge load cell		
Display	7-inch touchscreen color display (WSVGA)		
Operation method	Touchscreen (resistive film type), operation buttons		
Number of registrable products	1,000 products (10 groups x 100 products)		
Communication functions	RS-232C or RS-485 (for Modbus RTU, barcode reader *3, PC, PLC, dump printer, etc.)		
	Wireless LAN *4 *5 (for remote monitoring)		
	Wired LAN (for remote operation *6, Modbus TCP/IP and PostScript printer)		
	USB (for USB flash drive [Data storage and image import use] *7)		
External input/output	Input: Non-voltage contact input 8 points (option available to expand to max. 16 points) *8		
	Output: Relay output 8 points (option available to expand to max. 20 points) *8		
Dust-/water-proof	IP65		
Operation temperature / humidity range	0 to 40°C / humidity 85% or less (with no condensation)		
Power supply	Single phase AC100 to 240 V (+10% / -15%), 50 / 60 Hz, Approx. 180VA		
	Electric power source should be connected to terminal (M4).		
	Power cable should be provided by the customer.		
Weight *2	Approx. 35 kg		Approx. 50 kg
Material	Weighing unit: Stainless steel and PP resin Display: ABS resin		
	Conveyor unit: Aluminum (alumite coating), stainless steel and PP resin		
	Control unit: Stainless steel, PP resin and PE resin Base unit: Stainless steel		

*1 Depends on the shape and the condition of the product and installation environment

*2 Weight is for the standard condition without option and/or Rejector.

*3 Barcode reader shall be prepared by the customer.

*4 Reception sensitivity of wireless LAN depends on radio wave environment. For continuous monitoring, it is recommended to use a combination of the HMI indicator and the Modbus communication function via RS-485 or wired LAN as communication may be interrupted.

*5 Wireless LAN can be used depending on the regulations in your region.

*6 An Internet connection and a system for remote operation are required. Please consult with your sales staff for further detail.

*7 USB flash drive should be formatted in FAT32.

*8 Maximum number of input/output points that can be added will depend on the combination of additional input/output points. Please consult with your sales staff for further detail.

NOTE

Power cable is not included. Please prepare a ϕ 4-7mm cable.



Options

Stainless Steel Cover



Display Stand
AD-4961-01

Used to change the position of the display. Orientation of the display can also be adjusted.

Additional external output
4 points
AD-4961A-43-1
8 points
AD-4961A-43-2

Additional external input
8 points
AD-4961A-44

* Maximum number of input/output points that can be added will depend on the combination of additional input/output points.



Cross Plate for
AD-4961A-2KD2035
AD-4961-13

Tower Light (Comparator Light) *
AD-4961-02

Highly visible LED comparator light with 3 colors
Easily set on the Checkweigher DO map.
(Example: Red = Overweight, Yellow = Metal detected, Green = Pass)

* AD-4961-01 Display stand is required to mount this option.
Dust-/water-proof protection of the light part is IP53.

Upper Breeze Break
for AD-4961A-6001224/
AD-4961A-2KD2035

Height is adjustable in 3 steps.
Checkweighing can be done with the most suitable Breeze Break according to the object to be weighed.

Lower Breeze Break (Stainless steel)
for AD-4961A-2KD2035

* AD-4961A-6001224 is equipped with a lower breeze break as standard specification.

Rejector (Page 9 and 10)

Product Guide (Infeed Conveyor)
for AD-4961A-6001224
AD-4961-1236-14

Product Guide (Weighing Conveyor)
for AD-4961A-6001224
AD-4961-1224-14

Product Guide (Infeed and Weighing Conveyor)
for AD-4961A-2KD2035
AD-4961-14

Product Guide (Infeed or Weighing Conveyor)
for AD-4961A-6K3050
AD-4961-14-3050

Reject Confirmation Unit for Rejector



Sensor unit to confirm correct rejection of non-conforming product and/or correct passing of conforming product.
Number of sensors and their mounting positions can be selected as required.

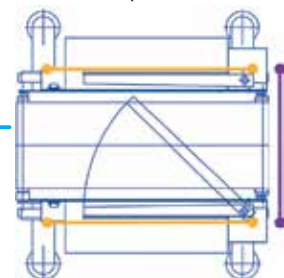

Calibration Weight

	OIML Class F1 Max. tolerance	Model
500 g	±2.5 mg	AD-1603-500F1
1 kg	±5.0 mg	AD-1603-1KF1
2 kg	±10 mg	AD-1603-2KF1
5 kg	±25 mg	AD-1603-5KF1



AD-1603-500F1



AD-1603-5KF1

A&D Inspection Systems

Metal Detector AD-4976 Series



Check for metal contaminant
 Check for missing metal item (e.g. aluminum sachet)
 Or both inspections above simultaneously (option)
 Sensor head is separately available

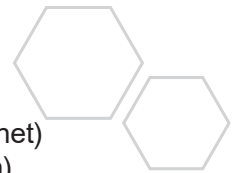

Model	Aperture width	Aperture height	Conveyor width	Maximum pass height
AD-4976-3510	350 mm	100 mm	250 mm	80 mm
AD-4976-3517	350 mm	170 mm	250 mm	150 mm
AD-4976-3525	350 mm	250 mm	250 mm	230 mm
AD-4976-4517	450 mm	170 mm	350 mm	150 mm
AD-4976-4525	450 mm	250 mm	350 mm	230 mm

X-ray Inspection System AD-4991 Series



Contaminant inspection not only for metal, but also other materials such as for resin, glass, rubber, stone, etc., with high detection sensitivity by contrast adjustment function. Other inspections such as Count, Position, Shape, Weight estimation can be performed simultaneously as standard specification. Missing inspection and Seal inspection can also be performed as options.

Model	Conveyor width	Maximum X-ray power output
AD-4991-2510	250 mm	100 W (50 kV_2 mA)
AD-4991-2515	250 mm	150 W (50 kV_3 mA)
AD-4991-3530	350 mm	300 W (75 kV_4 mA)



Automatic sorting of non-conforming products by the Rejector prevents human error and increases productivity.

Rejector automatically sorts conforming products and non-conforming products according to inspection results from A&D's inspection system.

Select a sorting system according to the shape of the product, etc.

Line-up

Flipper Type

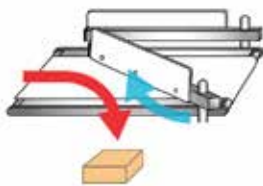

Conveyor Drop Type

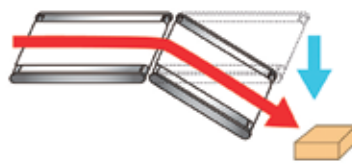

Pusher Type

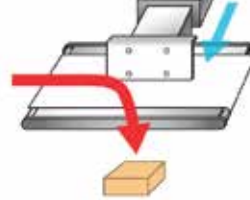

Air Jet Type

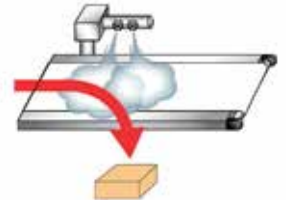

Flipper Type AD-4981 Series

Arm swings to automatically reject non-conforming products off the conveyor. Most versatile of the sorting methods and is ideal for boxes, tall bags and cases.



Box / Case

Tall bag

Rejection direction
Max. 3 ways

Model	AD-4981-2057	AD-4981-2570	AD-4981-3585
Conveyor belt width	200 mm	250 mm	350 mm
Screening capacity *1	120 pcs/min	100 pcs/min	80 pcs/min
Conveyor belt speed	15 to 120 m/min	10 to 80m/min	10 to 50 m/min
Air supply *2	0.5Mpa 0.2 NL/time Φ6 mm Polyurethane tube		0.5Mpa 0.4 NL/time Φ6 mm Polyurethane tube

Conveyor Drop Type AD-4982 Series

Non-conforming products are automatically rejected down the conveyor by the movement of the conveyor. Suitable for thin bags and sheet-like materials.



Thin bag *3

Sheet-like material

Rejection direction
Max. 2 ways

Model	AD-4982-2035	AD-4982-2540	AD-4982-3550
Conveyor belt width	200 mm	250 mm	350 mm
Screening capacity *1	150 pcs/min	100 pcs/min	60 pcs/min
Conveyor belt speed	15 to 120 m/min	10 to 80 m/min	10 to 50 m/min
Air supply *2	0.5Mpa 0.3 NL/time Φ6 mm Polyurethane tube		0.5Mpa 0.9 NL/time Φ6 mm Polyurethane tube

Photo: Conveyor Drop Type Rejector with optional base unit



Pusher Type AD-4983 Series



Non-conforming products are pushed off the conveyor.
Most suitable for boxes or tall bags.

Box

Tall bag

Rejection direction
Max. 2 ways

Model	AD-4983-3050	
Conveyor belt width	300 mm	
Screening capacity *1	60 pcs/min	
Conveyor belt speed	10 to 80 m/min	
Air supply *2	0.5Mpa 2.6 NL/time Φ8 mm Polyurethane tube	

Air Jet Type AD-4984 Series



Air is blown to automatically reject non-conforming products off the conveyor.
Ideal for small, light, individually packaged products and enables high-speed sorting.

Small, light,
individually
packaged product

High speed
rejection

Rejection direction
Max. 3 ways

Model	AD-4984-1246	AD-4984-2046
Conveyor belt width	120 mm	200 mm
Screening capacity *1	400 pcs/min	320 pcs/min
Conveyor belt speed	15 to 120 m/min	
Air supply *2	0.5Mpa 2.4 NL/time Φ10 mm Polyurethane tube	

*1 Actual screening capacity is dependent on the shape and/or the condition of the screened item and/or environment of the installation room.

*2 Please prepare compressed air with an air tube (polyurethane tube) to be connected to the filter regulator of the Rejector.

*3 Max. height of screened products is dependent on the shape of the conveyor downstream of the Conveyor Drop type Rejector.

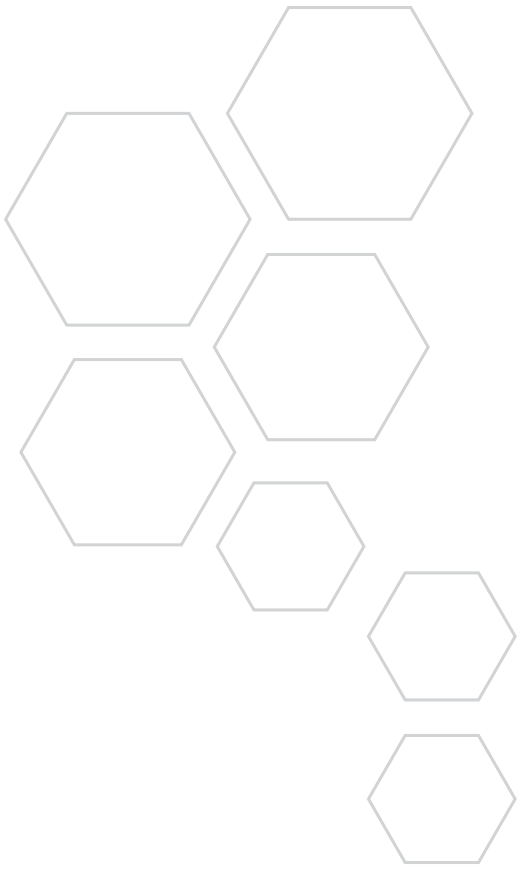

Discover Precision

A&D Company, Ltd. (JAPAN)
aandd.jp

A&D Australasia Pty Ltd. (Australia)
andaustralasia.com.au

A&D Engineering, Inc. (USA)
andonline.com

A&D Instruments Ltd. (United Kingdom)
andprecision.com

< German Sales Office >
andprecision.com

A&D Korea Ltd. (South Korea)
andk.co.kr

A&D Rus Co., Ltd. (Russia)
and-rus.ru

A&D Instruments India (P) Ltd. (India)
aanddindia.in

A&D Scientech Taiwan Ltd. (Taiwan)
aandd.com.tw

A&D Instruments Thailand Ltd. (Thailand)
thai.andprecision.com